

PICTURE D2

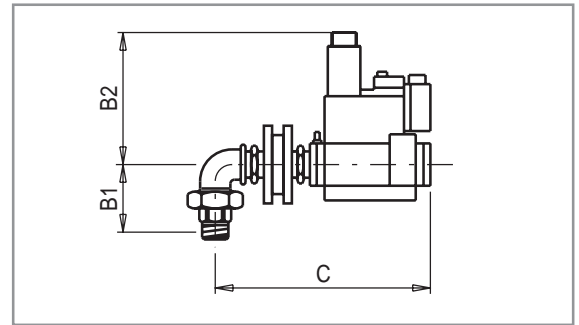
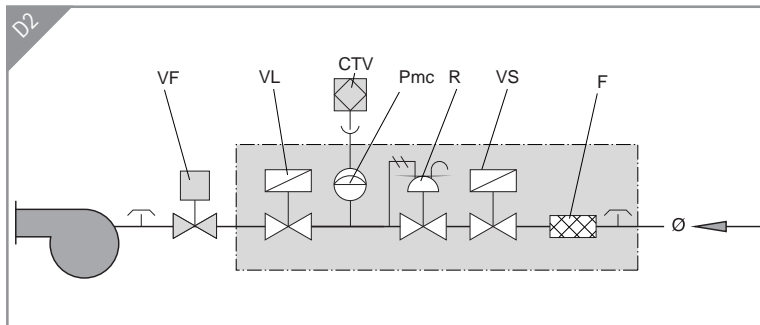

Gas train part no.	F	CTV	Pmc	Position			Ø	Gas train dimensions mm			Size of packaging mm L x P x H	Weight kg	
				R	VF	VL		VS	B1	B2			C
19990500 (MB... 410)	●	●	●	●	DK32	●	●	1"1/4	103	162	385	650 x 500 x 380	15
19990501 (MB... 412)	●	●	●	●	DK32	●	●	1"1/4	103	162	385	650 x 500 x 380	15
19990502 (MB... 415)	●	●	●	●	DK40	●	●	1"1/2	103	170	430	650 x 500 x 380	18
19990503 (MB... 420)	●	●	●	●	DK50	●	●	2"	114	220	445	650 x 500 x 380	20
19990504 (VGD20.50)	●	●	●	●	DK50	●	●	2"	114	255	1080	990 x 300 x 500	24
19990505 (VGD40.065)	●	●	●	●	DK65	●	●	DN65	207	291	1225	1380 x 430 x 710	50
19990506 (VGD40.080)	●	●	●	●	DK80	●	●	DN80	210	298	1350	1380 x 430 x 710	57

Legend

CTV - Valve tightness control	Pmin - Minimum pressure switch	RP - Pneumatic regulator	VPS - VPS valve tightness control
F - Filter	R - Pressure regulator	VF - Regulator throttle valve	VS - Safety valve
LDU - LDU valve tightness control	RF - Pressure regulator with filter	VL - Operating valve	VSP - Safety pilot valve
Pct - Pressure switch for gas control	RFP - Pressure regulator with filter for pilot gas train	VL2 - Two-stage operating valve	Ø - Gas train diameter
Pmax - Maximum pressure switch	RM - Manual flow rate regulator	VLP - Operating pilot valve	Ø1 - Main gas train diameter
Pmc - Minimum and control pressure switch gas leaks		VP - Pilot valve	Ø2 - Pilot gas train diameter



By inserting the RWF40 kit and the modulating kit into the two progressive stage burners, these are transformed into modulating burners, that is, with the capacity to provide thermal power which can be varied continuously in accordance with the specific needs of the boiler. Naturally, the thermal power level varies only within the "minimum" and "maximum" limits applying to the burner.

Selecting modulation kit components

With reference to parameter: temperature (°C) or pressure (bar), select the regulation range corresponding to the operating value of the boiler. When the value falls within two different setting ranges, select the lower of the two.

Example:

If the temperature of the water in the boiler is to be 100°C, choose the modulation kit corresponding to range 0 - 130°C. If the pressure of the steam in the boiler is to be 8 bar, select the modulation kit in the regulation range 0 - 10 bar.

RWF 40 electronic regulator for all modulating burners, used to regulate temperature or pressure.

Automatic proportional modulation regulator

Part no.	Model
98000051	Kit RWF 40
98000052	Kit RWF 40 for BGS 30 LX



Temperature modulation kit

Part no.	Temperature	Type probe	Probe length	Male coupling
98000020	0 °C - 130 °C	NI 1000	100 1)	R 1/2"
98000021	0 °C - 500 °C	PT 1000	200 1)	G 1/2"
98000022	0 °C - 1100 °C	Thermocouple	425 1)	R 1/2"



Steam pressure modulation kit

Part no.	Steam pressure	Male coupling
98000025	0 - 1 bar	G 1/2"
98000026	0 - 10 bar	G 1/2"
98000027	0 - 16 bar	G 1/2"
98000028	0 - 25 bar	G 1/2"
98000029	0 - 40 bar	G 1/2"

Notes

For different modulation values please contact our Technical Assistance Service.
1) Different lengths on request.