

### TECHNICAL AND FUNCTIONAL CHARACTERISTICS

- Gas-fired burner.
- Two-stage operation (high/low flame).
- Ability to operate with any type of combustion chamber.
- Air-gas mixing at blast-pipe.
- Ability to obtain optimal combustion values by regulating combustion air and blast-pipe.
- Maintenance facilitated by the fact that the mixing unit can be removed without having to remove the burner from the boiler.
- Air flow regulation for first and second stage by means of electric servomotor with pause closure of gate to prevent any heat dispersion to flue.
- Valves tightness control compliant with European standard EN676 in the CE execution; on request in the EXP execution.
- Equipped with one flange and one insulating seal for boiler fastening.

### CONSTRUCTION CHARACTERISTICS

The burner consists of:

- Light aluminium alloy fan part.
- High performance centrifugal fan.
- Combustion air intake with air flow adjustment device.
- Sliding boiler coupling flange to adapt the head protrusion to the various types of boilers.
- Adjustable blast-pipe with stainless steel nozzle and deflector disk in steel.
- Three-phase electric motor to run fan.
- Air pressure switch to ensure the presence of combustion air.
- Gas train complete with operation and safety valve, valves seal control, minimum pressure switch, pressure regulator and gas filter.
- Automatic control and command equipment for the burner, compliant with European standard EN298.
- Flame detection by ionisation electrode.
- Control panel comprising stop/go switch, 1st/2nd stage selector, operation and block indicator.
- Terminal block for the electrical and thermostatic connections to the burner and to control the second stage of working.
- Electrical protection rating IP40.

Conforms to:  
 Gas Directive 90/396/CEE  
 E.M.C. Directive 89/336/CEE  
 L.V. Directive 73/23/CEE  
 Reference standard: EN676

Thermal output kW	Model	Part no.	Electrical supply	Motor kW	A mm	B 1 mm	B 5 mm	C mm	D mm	F mm	Size of packaging L x P x H mm	Weight kg	Notes
<b>Frequency 50 Hz</b>													
414 - 1428	BGN 150	16660010	3N AC 50Hz 400V	2.2	655	450	137	1500	220 - 440	195	1730 x 1030 x 880	148	4)
590 - 2000	BGN 200	16710010	3N AC 50Hz 400V	3	830	580	150	1850	300 - 600	220	2030 x 1210 x 990	220	4)
490 - 2500	BGN 250	16760010	3N AC 50Hz 400V	7.5	875	580	150	1850	300 - 600	220	2030 x 1210 x 990	249	4)
657 - 2982	BGN 300	16810010	3N AC 50Hz 400V	7.5	875	580	177	1850	275 - 465	275	2030 x 1210 x 990	286	4)
924 - 3500	BGN 350	16860010	3N AC 50Hz 400V	7.5	880	580	177	1850	275 - 465	275	2030 x 1210 x 990	290	4)

### Accessories available on request

Part no.	Description
97980055	Soundproof burner cover for BGN 150
97980057	Soundproof burner cover for BGN 200-250-300-350

### Gas burner accessories

Boiler coupling kit

### Notes

- 4) Equipped with automatic device for air closing.
  - 6) Where gas pressure at the safety valve is less than 12mbar, replace the minimum pressure switch with a GW50 pressure switch.
  - 7) Regulator and filter are supplied separately: both must be ordered.
- CTV) Gas train with Valve Tightness Control.
- \*) Minimum gas train inlet pressure needed to obtain maximum burner power with a combustion chamber backpressure of zero.
- \*\*) Maximum gas pressure at pressure regulator in CE version, at gas train for EXP version.

Net calorific value of natural gas:  $H_i = 35.80 \text{ MJ/m}^3 = 8550 \text{ kcal/m}^3$ , at reference conditions of  $0^\circ\text{C}$ , 1013 mbar.

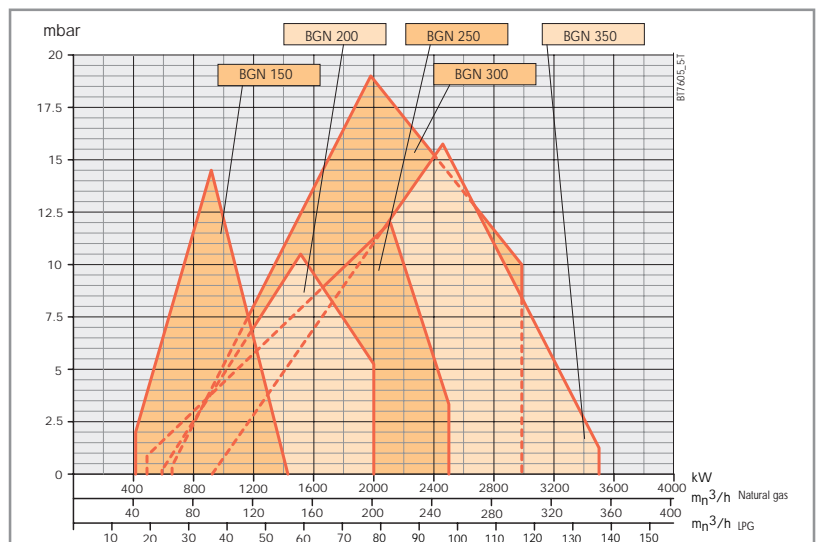



PICTURE B2

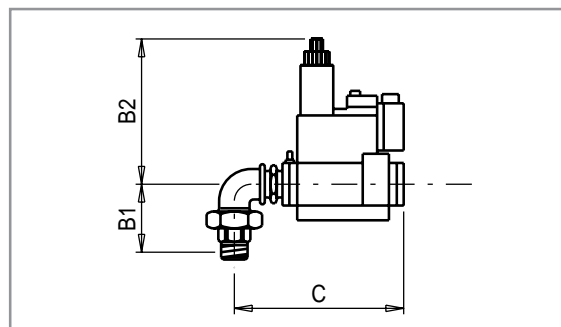
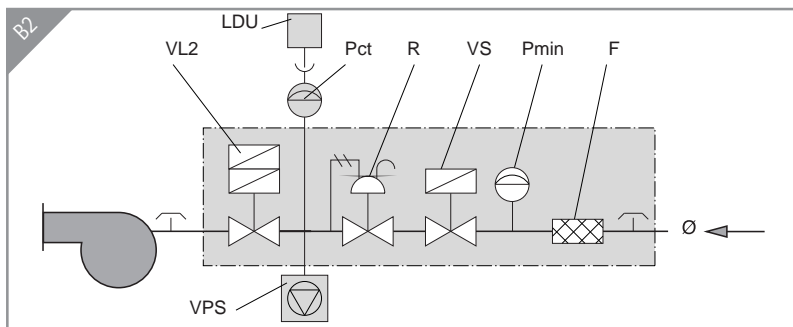

Gas train part no.	F	LDU	Pct	Pmin	Position		VL2	VPS	VS	Ø	Gas train dimensions			Size of packaging mm L x P x H	Weight kg
					R						mm	B2	C		
19990016 (MB... 405)	●			●	●		●		●	3/4"	72	210	204	310 x 210 x 350	5
19990020 (MB... 407)	●			●	●		●		●	3/4"	72	210	204	310 x 210 x 350	5
19990024 (MB... 410)	●			●	●		●		●	1 <sup>1</sup> / <sub>4</sub> "	95	260	249	310 x 210 x 350	8
19990168 (MB... 412)	●			●	●		●		●	1 <sup>1</sup> / <sub>4</sub> "	95	260	249	310 x 210 x 350	8
19990404 (MB... 415)	●			●	●		●		●	1 <sup>1</sup> / <sub>2</sub> "	103	270	311	520 x 410 x 460	11
19990405 (MB... 420)	●			●	●		●		●	2"	114	330	367	520 x 410 x 460	13
19990410 (MB... 412)	●			●	●		●		●	1 <sup>1</sup> / <sub>4</sub> "	103	260	255	520 x 410 x 460	9
19990411 (MB... 410)	●			●	●		●		●	1 <sup>1</sup> / <sub>4</sub> "	103	260	255	520 x 410 x 460	9
19990454 (MB... 415)	●	●	●	●	●		●		●	1 <sup>1</sup> / <sub>2</sub> "	103	270	311	520 x 410 x 460	12
19990455 (MB... 420)	●	●	●	●	●		●		●	2"	114	330	367	520 x 410 x 460	14

PICTURE B4

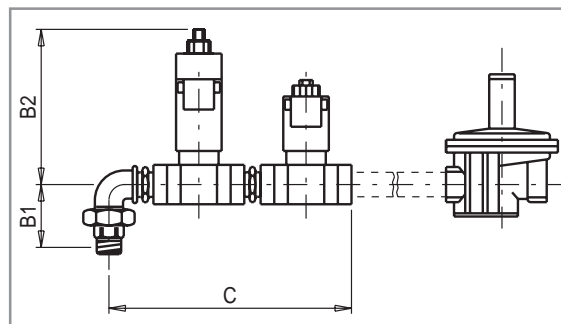
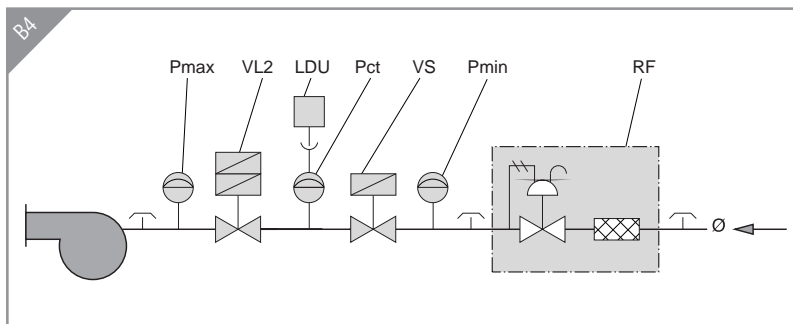

Gas train part no.	LDU	Pct	Pmax	Position		VL2	VS	Ø	B1	Gas train dimensions		Size of packaging mm L x P x H	Weight kg
				Pmin	RF					mm	B2		
19990436	●	●	●	●	1"	3/4"	3/4"	1"	72	235	256	520 x 410 x 460	11
19990438	●	●	●	●	1 <sup>1</sup> / <sub>2</sub> "	1"	1"	1 <sup>1</sup> / <sub>2</sub> "	83	235	296	520 x 410 x 460	13
19990456			●	●	DN65	2"	2"	DN65	114	305	454	520 x 410 x 460	20
19990457	●	●	●	●	DN65	2"	2"	DN65	114	305	454	520 x 410 x 460	21
19990458			●	●	DN65	2"	DN65	DN65	114	305	682	830 x 430 x 620	36
19990459	●	●	●	●	DN65	2"	DN65	DN65	114	305	682	830 x 430 x 620	37

**Legend**

CTV - Valve tightness control	Pmin - Minimum pressure switch	RP - Pneumatic regulator	VPS - VPS valve tightness control
F - Filter	R - Pressure regulator	VF - Regulator throttle valve	VS - Safety valve
LDU - LDU valve tightness control	RF - Pressure regulator with filter	VL - Operating valve	VSP - Safety pilot valve
Pct - Pressure switch for gas control	RFP - Pressure regulator with filter for pilot gas train	VL2 - Two-stage operating valve	Ø - Gas train diameter
Pmax - Maximum pressure switch	RM - Manual flow rate regulator	VLP - Operating pilot valve	Ø1 - Main gas train diameter
Pmc - Minimum and control pressure switch gas leaks		VP - Pilot valve	Ø2 - Pilot gas train diameter

PICTURE BE4

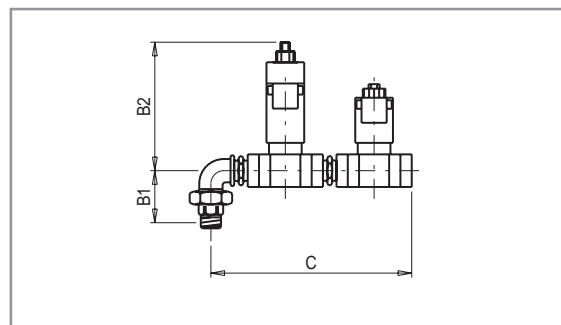
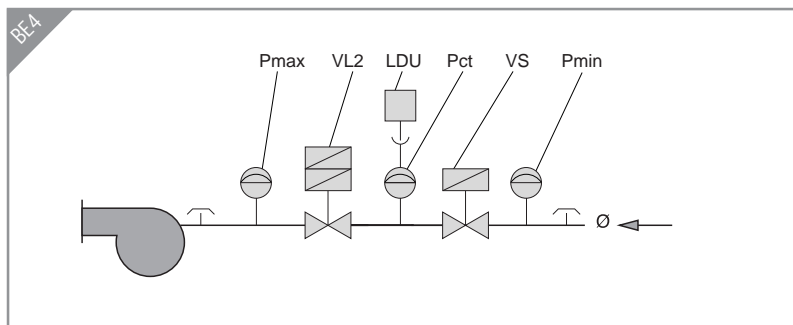

Gas train part no.	Gas train components							Gas train dimensions mm			Size of packaging mm L x P x H	Weight kg
	LDU	Pct	Pmax	Position Pmin	VL2	VS	Ø	B1	B2	C		
19990436	●	●	●	●	3/4"	3/4"	3/4"	72	235	256	520 x 410 x 460	11
19990438	●	●	●	●	1"	1"	1"	83	235	296	520 x 410 x 460	13
19990456			●	●	2"	2"	2"	114	305	454	520 x 410 x 460	20
19990457	●	●	●	●	2"	2"	2"	114	305	454	520 x 410 x 460	21
19990458			●	●	2"	DN65	DN65	114	305	682	830 x 430 x 620	36
19990459	●	●	●	●	2"	DN65	DN65	114	305	682	830 x 430 x 620	37

PICTURE BE5

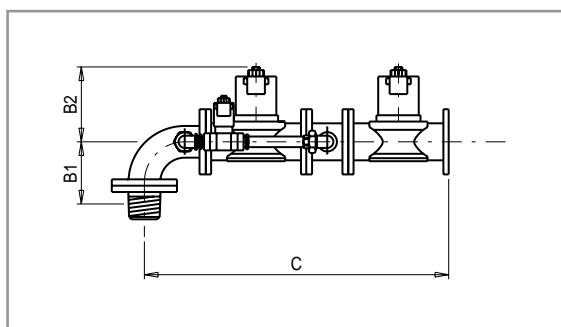
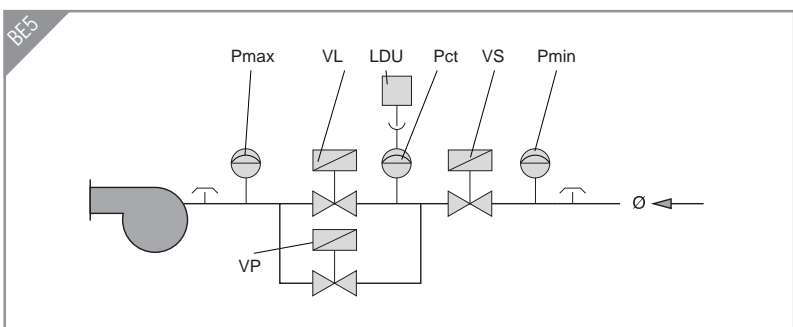

Gas train part no.	Gas train components								Gas train dimensions mm			Size of packaging mm L x P x H	Weight kg
	LDU	Pct	Pmax	Position Pmin	VL	VP	VS	Ø	B1	B2	C		
19990460			●	●	DN65	1"1/2	DN65	DN65	207	295	969	1260 x 660 x 670	63
19990461	●	●	●	●	DN65	1"1/2	DN65	DN65	207	295	969	1260 x 660 x 670	64
19990462			●	●	DN80	1"1/2	DN80	DN80	210	320	1016	1320 x 690 x 670	97
19990463	●	●	●	●	DN80	1"1/2	DN80	DN80	210	320	1016	1320 x 690 x 670	98
19990464			●	●	DN100	1"1/2	DN100	DN100	242	385	1125	1320 x 690 x 670	103
19990465	●	●	●	●	DN100	1"1/2	DN100	DN100	242	385	1125	1320 x 690 x 670	104

## Legend

CTV - Valve tightness control	Pmin - Minimum pressure switch	RP - Pneumatic regulator	VPS - VPS valve tightness control
F - Filter	R - Pressure regulator	VF - Regulator throttle valve	VS - Safety valve
LDU - LDU valve tightness control	RF - Pressure regulator with filter	VL - Operating valve	VSP - Safety pilot valve
Pct - Pressure switch for gas control	RFP - Pressure regulator with filter for pilot gas train	VL2 - Two-stage operating valve	Ø - Gas train diameter
Pmax - Maximum pressure switch	RM - Manual flow rate regulator	VLP - Operating pilot valve	Ø1 - Main gas train diameter
Pmc - Minimum and control pressure switch gas leaks		VP - Pilot valve	Ø2 - Pilot gas train diameter

PICTURE B5

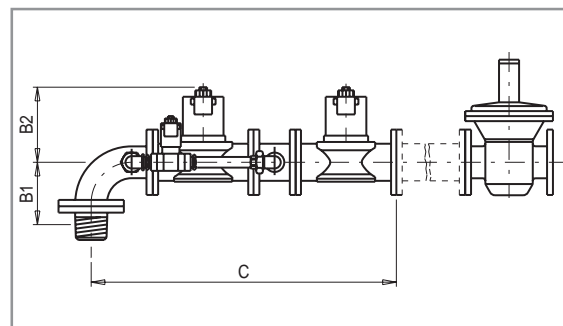
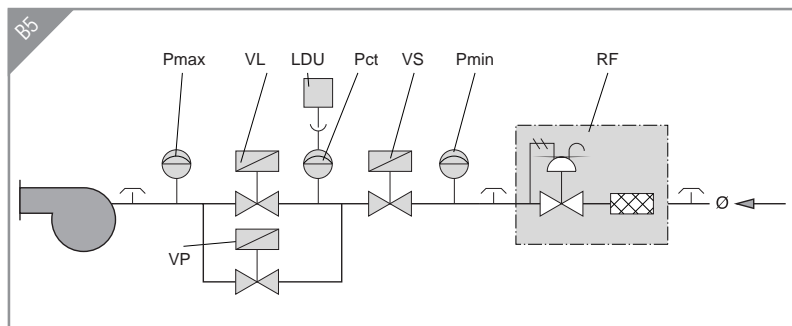

Gas train part no.	Position									Gas train dimensions mm			Size of packaging mm L x P x H	Weight kg
	LDU	Pct	Pmax	Pmin	RF	VL	VP	VS	Ø	B1	B2	C		
19990460			●	●	DN65	DN65	1*1/2	DN65	DN65	207	295	969	1260 x 660 x 670	63
19990461	●	●	●	●	DN65	DN65	1*1/2	DN65	DN65	207	295	969	1260 x 660 x 670	64
19990462			●	●	DN80	DN80	1*1/2	DN80	DN80	210	320	1016	1320 x 690 x 670	97
19990463	●	●	●	●	DN80	DN80	1*1/2	DN80	DN80	210	320	1016	1320 x 690 x 670	98
19990465	●	●	●	●	DN100	DN100	1*1/2	DN100	DN100	242	385	1125	1320 x 690 x 670	104

## Legend

CTV - Valve tightness control	Pmin - Minimum pressure switch	RP - Pneumatic regulator	VPS - VPS valve tightness control
F - Filter	R - Pressure regulator	VF - Regulator throttle valve	VS - Safety valve
LDU - LDU valve tightness control	RF - Pressure regulator with filter	VL - Operating valve	VSP - Safety pilot valve
Pct - Pressure switch for gas control	RFP - Pressure regulator with filter for pilot gas train	VL2 - Two-stage operating valve	Ø - Gas train diameter
Pmax - Maximum pressure switch	RM - Manual flow rate regulator	VLP - Operating pilot valve	Ø1 - Main gas train diameter
Pmc - Minimum and control pressure switch gas leaks		VP - Pilot valve	Ø2 - Pilot gas train diameter

Using the specific diagrams, it is possible to select the gas train that is most suitable for the burner.

First of all it is necessary to identify:

- Burner's heat input  $Q_i$  [kW], to be identified along the x-coordinate.
- Gas pressure available at the regulator  $P_g$  [mbar], to be identified along the y-coordinate.

The available gas pressure is determined by the formula:  $P_g = P_a - P_c$

where:

- $P_a$  = gas pressure provided by the mains supply;
- $P_c$  = the pressure in the boiler combustion chamber.

The intersection point of the two lines defines the operational parameters of the gas train.

The gas train characterised by the first curve underneath the intersection point must be chosen.

### EXAMPLE

- Burner = BGN 200P
  - $Q_i = 1700$  kW
  - $P_a = 44.5$  mbar
  - $P_c = 2.5$  mbar
  - $P_g = 44.5 - 2.5 = 42$  mbar
- Choose the indicated curve 20C.

The red segment of the curve indicates that the neutral-coloured spring of the regulator must be replaced with the red one (supplied).

To identify the codes for the gas train, pressure regulator and adapter to be ordered refer to the BURNER/TRAIN MATCH-UP TABLE relative to burner BGN200P and CURVE REFERENCE 20C.

### Note:

In the graphs the head loss curves have different colours.

The mono-colour BLUE curve represents a gas train with a monoblock valve. The mono-colour ORANGE curve represents a gas train with a mono-valve or with separate valves without pressure regulator; this execution does not comply with EN676 regulation.

The multi-colour curve represents a gas train with separate valves and pressure regulator (this version complies with EN676 regulation). The coloured segments identify the colour of the spring with which the regulator should be used under those specific flow rate/pressure conditions. The pressure regulator is supplied with different-coloured springs (green, red and violet): these are used to replace the one already installed (neutral colour) at the time of installation if necessary.

