

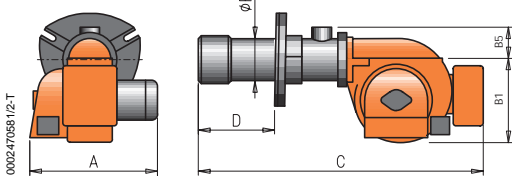

0085



TECHNICAL AND FUNCTIONAL CHARACTERISTICS

- Gas-fired burner.
- Two-stage progressive output operation.
- Ability to operate with output modulation by means of automatic RWF40 regulator mounted on the control panel (to be ordered separately with the modulation kit).
- Ability to operate with any type of combustion chamber.
- Air-gas mixing at blast-pipe.
- Ability to obtain optimal combustion values by regulating combustion air and blast-pipe.
- Maintenance facilitated by the fact that the mixing unit can be removed without having to remove the burner from the boiler.
- Minimum/maximum air flow adjustment by means of electric servo step motor with air gate closure in pause to avoid heat loss to flue.
- Valves tightness control device compliant with European standard EN676.
- Equipped with one flange and one insulating seal for boiler fastening.

CONSTRUCTION CHARACTERISTICS

The burner consists of:

- Light aluminium alloy fan part.
- High performance centrifugal fan.
- Combustion air intake with air flow adjustment device.
- Sliding boiler coupling flange to adapt the head

protrusion to the various types of boilers.

- Adjustable blast-pipe with stainless steel nozzle and deflector disk in steel.
- Three-phase electric motor to run fan.
- Air pressure switch to ensure the presence of combustion air.
- Electric servo step motors for simultaneous control of combustion air and fuel.
- In the CE version gas train complete with control, operating and safety valve, valve tightness control, minimum and maximum pressure switch, pressure regulator and gas filter; in the EXPORT version gas train complete with control, operating and safety valve, valve tightness control, minimum and maximum pressure switch.
- Burner automatic command and control equipment with microprocessor (electronic cam) in compliance with European standard EN298, with valve tightness control and eBus connection. Display for operating sequence, modulation percentage, and error code in the event of a lockout.
- Flame detection by ionisation electrode.
- Control panel with burner Stop/Go switch, automatic/manual and minimum/maximum selector operation and block indicators.
- Terminal block for the electrical and thermostatic connections to the burner and to control the second stage of working or for the connection of the electronic output regulator.
- Electrical protection rating IP40.

LPG version available: please contact sales office for quote.

Conforms to:
 Gas Directive 90/396/CEE
 E.M.C. Directive 89/336/CEE
 L.V. Directive 73/23/CEE
 Reference standard: EN676

Thermal output kW	Model	Part no.	Electrical supply	Motor kW	A mm	B 1 mm	B 5 mm	C mm	D mm	F mm	Size of packaging L x P x H mm	Weight kg	Notes
-------------------	-------	----------	-------------------	----------	------	--------	--------	------	------	------	--------------------------------	-----------	-------

Frequency 50 Hz

590 - 2000	BGN 200 Mod ME	16720050	3N AC 50Hz 400V	3	830	580	150	1850	300 - 600	220	2030 x 1210 x 990	220	4)
------------	----------------	----------	-----------------	---	-----	-----	-----	------	-----------	-----	-------------------	-----	----

Modulating mode

Complete the burner with the automatic RWF40 regulator and the modulation kit.

Gas burner accessories

Boiler coupling kit

Notes

- 4) Equipped with automatic device for air closing.
 *) Minimum gas train inlet pressure needed to obtain maximum burner power with a combustion chamber backpressure of zero.
 Net calorific value of natural gas: $H_i = 35.80 \text{ MJ/m}^3 = 8550 \text{ kcal/m}^3$, at reference conditions of 0°C , 1013 mbar.

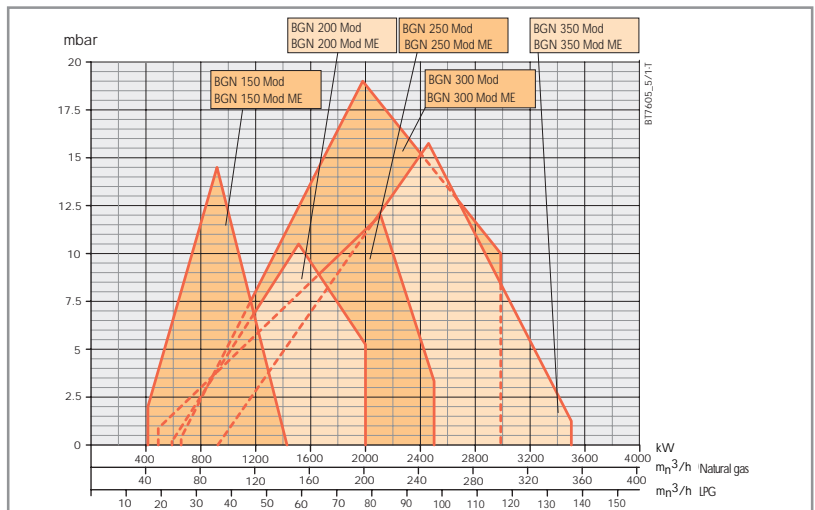

Burner model	Gas type	Version	Curve on graph	P.Max** mbar	Gas train		Regulator with incorporated filter		Burner/gas train adapter		Pic.	Notes
					Part no.		Part no.		Part no.			
BGN 200 Mod ME	NATURAL	CE / EXP	57A	360	19990502		Included		96000011		D2	
			57B	360	19990503		Included		96000012		D2	
			57C	500	19990504		Included		96000012		D2	
			57D	500	19990505		Included		96005003		D2	
			57E	500	19990506		Included		96005004		D2	

Please see last page for Gas Train Calculations' Example

Head loss (combustion head + gas train + pressure regulator)
BGN 200 Modulating ME Natural gas
CE / EXP

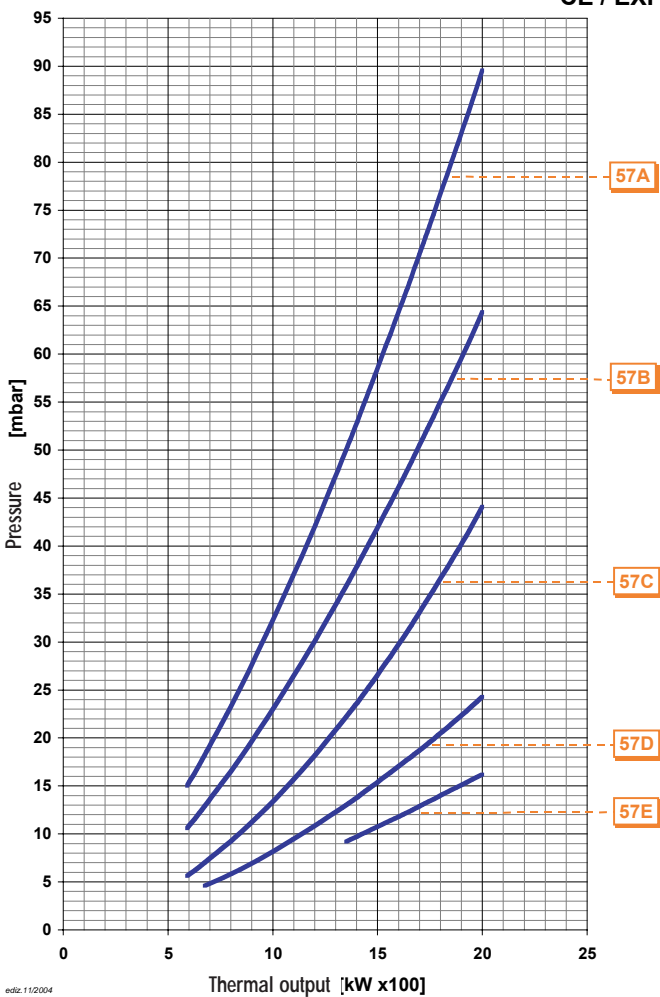

Flange Mounting Dimensions

L	M	N
339	M16	240

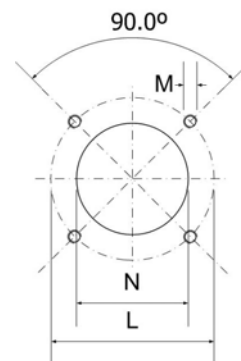

PICTURE D2

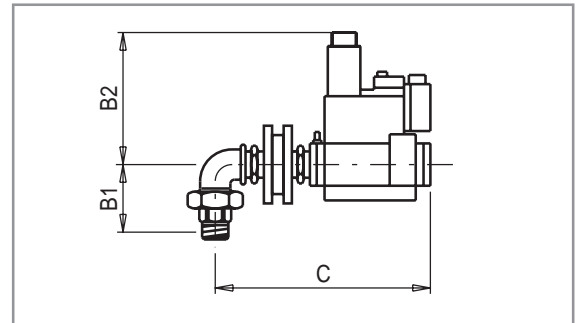
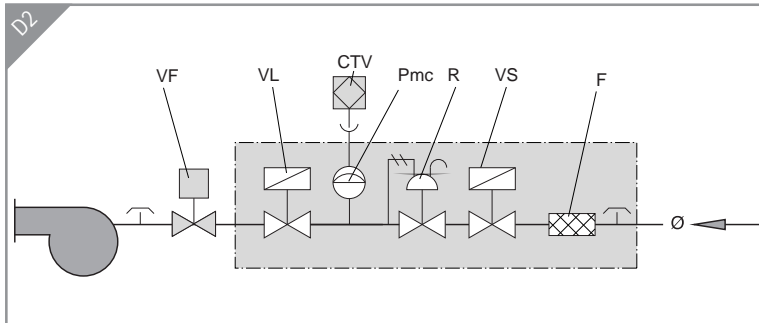

Gas train part no.	F	CTV	Pmc	Position			Ø	Gas train dimensions mm			Size of packaging mm L x P x H	Weight kg	
				R	VF	VL		B1	B2	C			
19990500 (MB... 410)	●	●	●	●	DK32	●	●	1"1/4	103	162	385	650 x 500 x 380	15
19990501 (MB... 412)	●	●	●	●	DK32	●	●	1"1/4	103	162	385	650 x 500 x 380	15
19990502 (MB... 415)	●	●	●	●	DK40	●	●	1"1/2	103	170	430	650 x 500 x 380	18
19990503 (MB... 420)	●	●	●	●	DK50	●	●	2"	114	220	445	650 x 500 x 380	20
19990504 (VGD20.50)	●	●	●	●	DK50	●	●	2"	114	255	1080	990 x 300 x 500	24
19990505 (VGD40.065)	●	●	●	●	DK65	●	●	DN65	207	291	1225	1380 x 430 x 710	50
19990506 (VGD40.080)	●	●	●	●	DK80	●	●	DN80	210	298	1350	1380 x 430 x 710	57

Legend

CTV - Valve tightness control	Pmin - Minimum pressure switch	RP - Pneumatic regulator	VPS - VPS valve tightness control
F - Filter	R - Pressure regulator	VF - Regulator throttle valve	VS - Safety valve
LDU - LDU valve tightness control	RF - Pressure regulator with filter	VL - Operating valve	VSP - Safety pilot valve
Pct - Pressure switch for gas control	RFP - Pressure regulator with filter for pilot gas train	VL2 - Two-stage operating valve	Ø - Gas train diameter
Pmax - Maximum pressure switch	RM - Manual flow rate regulator	VLP - Operating pilot valve	Ø1 - Main gas train diameter
Pmc - Minimum and control pressure switch gas leaks		VP - Pilot valve	Ø2 - Pilot gas train diameter



By inserting the RWF40 kit and the modulating kit into the two progressive stage burners, these are transformed into modulating burners, that is, with the capacity to provide thermal power which can be varied continuously in accordance with the specific needs of the boiler. Naturally, the thermal power level varies only within the "minimum" and "maximum" limits applying to the burner.

Selecting modulation kit components

With reference to parameter: temperature (°C) or pressure (bar), select the regulation range corresponding to the operating value of the boiler. When the value falls within two different setting ranges, select the lower of the two.

Example:

If the temperature of the water in the boiler is to be 100°C, choose the modulation kit corresponding to range 0 - 130°C. If the pressure of the steam in the boiler is to be 8 bar, select the modulation kit in the regulation range 0 - 10 bar.

RWF 40 electronic regulator for all modulating burners, used to regulate temperature or pressure.

Automatic proportional modulation regulator

Part no.	Model
98000051	Kit RWF 40
98000052	Kit RWF 40 for BGS 30 LX



Temperature modulation kit

Part no.	Temperature	Type probe	Probe length	Male coupling
98000020	0 °C - 130 °C	NI 1000	100 1)	R 1/2"
98000021	0 °C - 500 °C	PT 1000	200 1)	G 1/2"
98000022	0 °C - 1100 °C	Thermocouple	425 1)	R 1/2"



Steam pressure modulation kit

Part no.	Steam pressure	Male coupling
98000025	0 - 1 bar	G 1/2"
98000026	0 - 10 bar	G 1/2"
98000027	0 - 16 bar	G 1/2"
98000028	0 - 25 bar	G 1/2"
98000029	0 - 40 bar	G 1/2"

Notes

For different modulation values please contact our Technical Assistance Service.
1) Different lengths on request.

Using the specific diagrams, it is possible to select the gas train that is most suitable for the burner.

First of all it is necessary to identify:

- Burner's heat input Q_i [kW], to be identified along the x-coordinate.
- Gas pressure available at the regulator P_g [mbar], to be identified along the y-coordinate.

The available gas pressure is determined by the formula: $P_g = P_a - P_c$

where:

- P_a = gas pressure provided by the mains supply;
- P_c = the pressure in the boiler combustion chamber.

The intersection point of the two lines defines the operational parameters of the gas train.

The gas train characterised by the first curve underneath the intersection point must be chosen.

EXAMPLE

- Burner = BGN 200
 - $Q_i = 1700$ kW
 - $P_a = 44.5$ mbar
 - $P_c = 2.5$ mbar
 - $P_g = 44.5 - 2.5 = 42$ mbar
- Choose the indicated curve 20C.

The red segment of the curve indicates that the neutral-coloured spring of the regulator must be replaced with the red one (supplied).

To identify the codes for the gas train, pressure regulator and adapter to be ordered refer to the BURNER/TRAIN MATCH-UP TABLE relative to burner BGN200 and CURVE REFERENCE 20C.

Note:

In the graphs the head loss curves have different colours.

The mono-colour BLUE curve represents a gas train with a monoblock valve. The mono-colour ORANGE curve represents a gas train with a mono-valve or with separate valves without pressure regulator; this execution does not comply with EN676 regulation.

The multi-colour curve represents a gas train with separate valves and pressure regulator (this version complies with EN676 regulation). The coloured segments identify the colour of the spring with which the regulator should be used under those specific flow rate/pressure conditions. The pressure regulator is supplied with different-coloured springs (green, red and violet): these are used to replace the one already installed (neutral colour) at the time of installation if necessary.

