



CE 0085

TECHNICAL AND FUNCTIONAL CHARACTERISTICS

- Gas-fired burner.
- Two-stage progressive output operation.
- Ability to operate with output modulation by means of automatic RWF40 regulator mounted on the control panel (to be ordered separately with the modulation kit).
- Ability to operate with any type of combustion chamber.
- Air-gas mixing at blast-pipe.
- Burnt gas recycling blast-pipe able to achieve very low pollutant emissions, particularly with regard to nitrous oxides (NOx).
- Maintenance facilitated by the fact that the mixing unit can be removed without having to remove the burner from the boiler.
- Minimum and maximum air flow regulation for first and second stage by means of electric servomotor with pause closure of gate to prevent any heat dispersion to flue.
- Fan speed adjustment in relation to changes in burner demand provided by means of inverter, to obtain a significant reduction in noise levels and electricity consumption (version V only).
- Valves tightness control compliant with European standard EN676 in the CE execution; on request in the EXP execution.
- Equipped with one flange and one insulating seal for boiler fastening.

CONSTRUCTION CHARACTERISTICS

The burner consists of:

- Light aluminium alloy fan part.
- High performance centrifugal fan.
- Combustion air intake with air flow adjustment device.
- Sliding boiler coupling flange to adapt the head protrusion to the various types of boilers.
- Adjustable blast-pipe with stainless steel nozzle and deflector disk in steel.
- Three-phase electric motor to run fan (with electronic inverter control in version V).
- Air pressure switch to ensure the presence of combustion air.
- Monoblock modulating gas train complete with operation and safety valve, valves seal control, minimum pressure switch, pressure regulator and gas filter.
- Automatic control and command equipment for the burner, compliant with European standard EN298.
- Flame detection by ionisation electrode.
- Control panel comprising stop/go switch, automatic/manual and minimum/maximum selector, operation and block indicator.
- Terminal block for the electrical and thermostatic connections to the burner and to control the second stage of working or for the connection of the electronic output regulator.
- Electrical protection rating IP40.

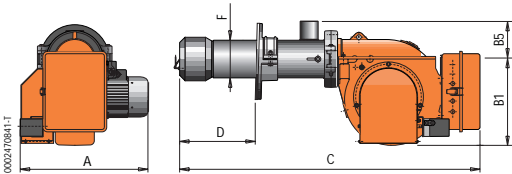

Conforms to:
 Gas Directive 90/396/CEE
 E.M.C. Directive 89/336/CEE
 L.V. Directive 73/23/CEE
 Reference standard: EN676

Thermal output kW	Model	Part no.	Electrical supply	Motor kW	A mm	B 1 mm	B 5 mm	C mm	D mm	F mm	Size of packaging L x P x H mm	Weight kg	Notes
Frequency 50 Hz													
250 - 2150	BGN 200 LX	15240010	3N AC 50Hz 400V	3	800	580	150	1740	280 - 480	220	2030 x 1210 x 990	240	4)
250 - 2150	BGN 200 LX V	15240015	3N AC 50Hz 400V	3	800	580	150	1740	280 - 480	220	2030 x 1210 x 990	248	4)
400 - 3600	BGN 300 LX	15260010	3N AC 50Hz 400V	7.5	845	580	177	1740	270 - 450	275	2030 x 1210 x 990	305	4)
400 - 3600	BGN 300 LX V	15260015	3N AC 50Hz 400V	7.5	845	580	177	1740	270 - 450	275	2030 x 1210 x 990	317	4)
400 - 3950	BGN 390 LX	15280010	3N AC 50Hz 400V	7.5	845	580	177	1740	270 - 450	275	2030 x 1210 x 990	310	4)
400 - 3950	BGN 390 LX V	15280015	3N AC 50Hz 400V	7.5	845	580	177	1740	270 - 450	275	2030 x 1210 x 990	322	4)

Accessories available on request

Part no.	Description
97980057	Soundproof burner cover

Modulating mode

Complete the burner with the automatic RWF40 regulator and the modulation kit

Gas burner accessories

Boiler coupling kit

Notes

- 4) Equipped with automatic device for air closing.
 CTV) Gas train with Valve Tightness Control.
 **) Maximum gas pressure at pressure regulator in CE version, at gas train for EXP version.
 Net calorific value of natural gas: $H_i = 35.80 \text{ MJ/m}^3 = 8550 \text{ kcal/m}^3$, at reference conditions of 0°C, 1013 mbar.

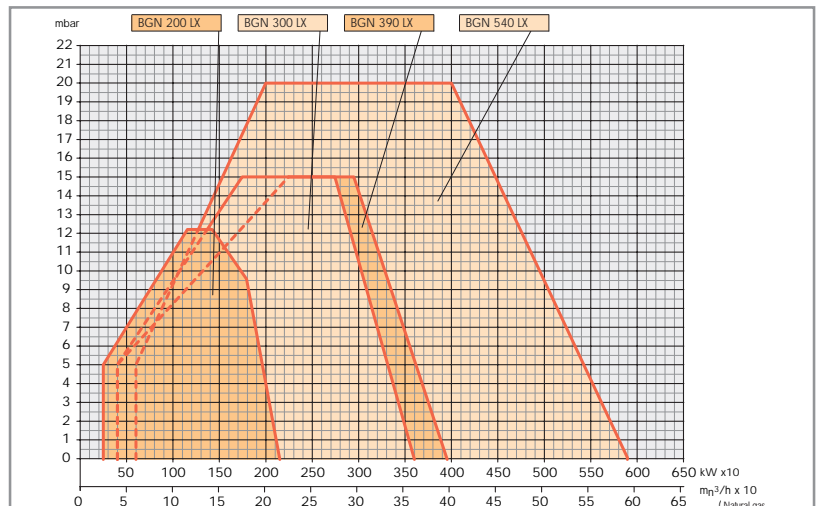

BURNER/GAS TRAIN MATCH - CE gas train version complies with EN676, EXP gas train version is for extra-European markets

Burner model	Gas type	Version	Curve on graph	Execution	P.Max** mbar	Gas train		Regulator with incorporated filter	Burner/gas train adapter		Valve tightness control kit		Pic.	Notes
						Part no.		Part no.		Part no.				
BGN 390LX	NATURAL	CE	30A		100	19990444	Included	96000012					D3	
					360	19990451	Included	96000012	Complete the gas train with the VPS.S02 kit part. no 98000101				D3	
					360	19990445	Included	96005004	Complete the gas train with the VPS.S02 kit part. no 98000101				D3	
					360	19990446	Included	96005004	Complete the gas train with the VPS.S02 kit part. no 98000101				D3	
					360	19990446	Included	96005004	Complete the gas train with the VPS.S02 kit part. no 98000101				D3	
	GAS	EXP	30J		100	19990444	Included	96000012			—		D3	
					360	19990451	Included	96000012			—		D3	
				CTV	100	19990444	Included	96000012		98000101		D3		
				CTV	360	19990451	Included	96000012		98000101		D3		
				CTV	360	19990445	Included	96005004		—		D3		
GAS	EXP	30K		360	19990445	Included	96005004			—		D3		
			CTV	360	19990445	Included	96005004		98000101		D3			
				360	19990446	Included	96005004		—		D3			
			CTV	360	19990446	Included	96005004		98000101		D3			
			CTV	360	19990446	Included	96005004		98000101		D3			

Head loss (combustion head + gas train + pressure regulator)

BGN 390LX Natural gas CE

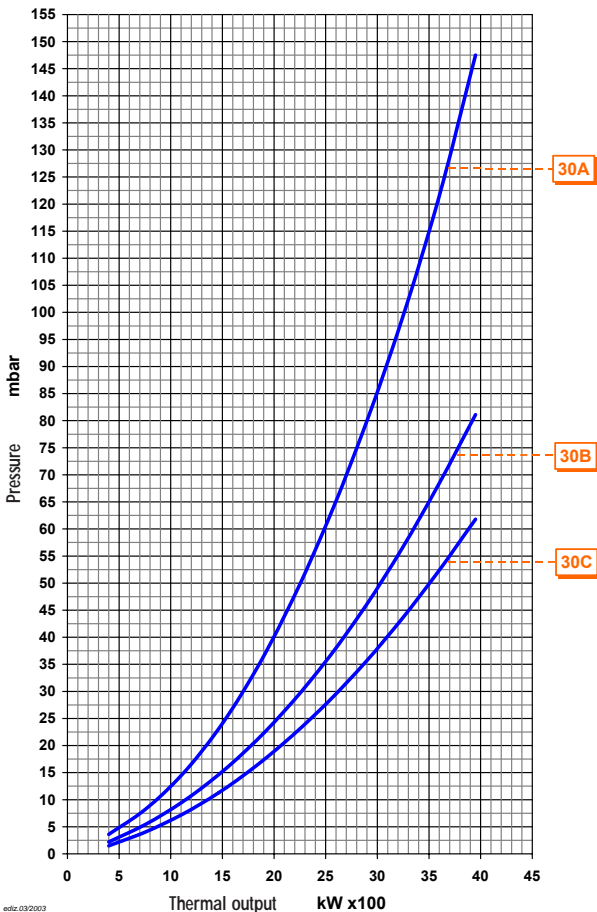

Head loss (combustion head + gas train + pressure regulator)

BGN 390LX Natural gas EXP

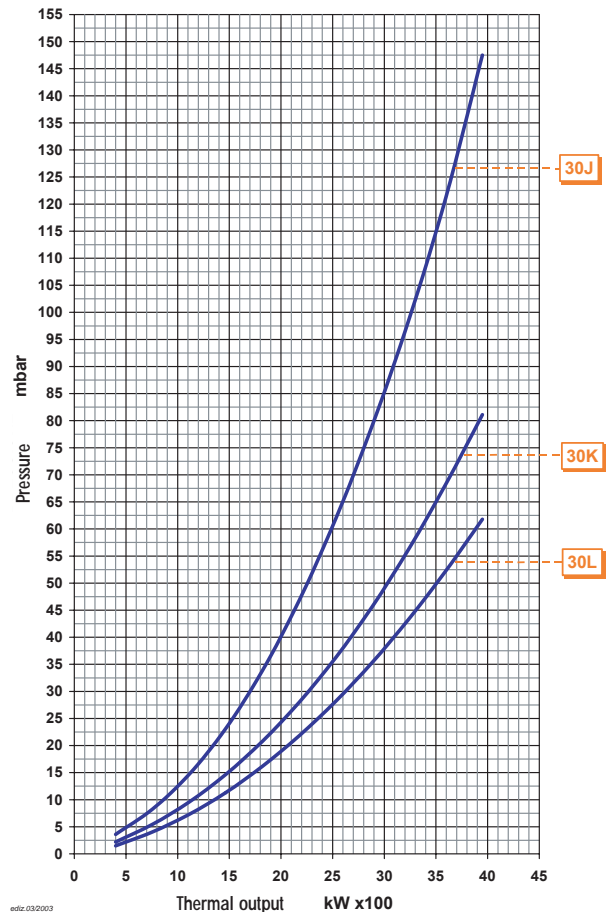

PICTURE D3

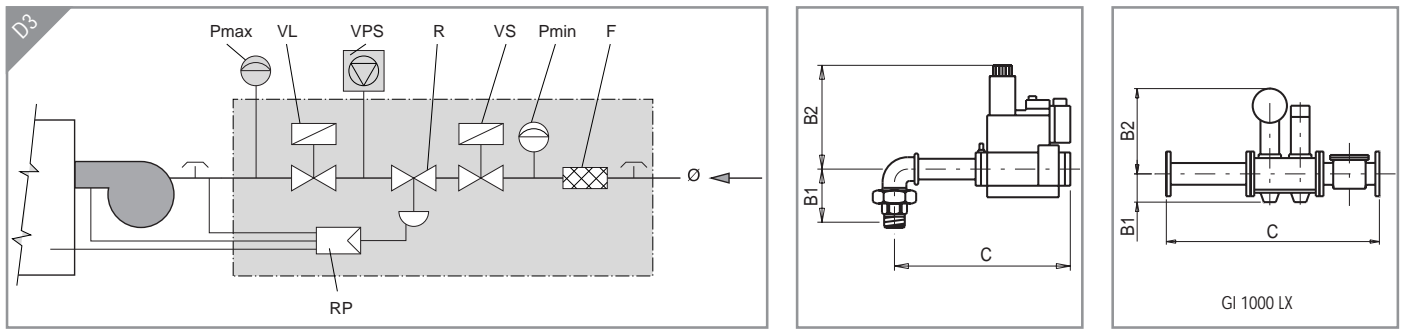

Gas train part no.	Position								Gas train dimensions			Size of packaging mm L x P x H	Weight kg	
	F	Pmax	Pmin	R	RP	VL	VPS	VS	Ø	B1	B2			C
19990440 (MB... 407)	●		●	●	●	●		●	3/4"	72	160	354	400 x 300 x 280	6
19990441 (MB... 412)	●		●	●	●	●		●	1 1/4"	95	175	500	520 x 410 x 460	9
19990442 (MB... 415)	●		●	●	●	●	▲	●	1 1/2"	103	185	643	650 x 500 x 380	12
19990443 (MB... 420)	●		●	●	●	●	▲	●	2"	114	225	711	990 x 300 x 500	13
19990444 (MB... 425)	●		●	●	●	●	▲	●	2"	114	291	951	990 x 300 x 500	19
19990445 (DMV... 5080)	●		●	●	●	●	▲	●	DN80	210	304	1430	1380 x 430 x 710	70
19990446 (DMV... 5100)	●		●	●	●	●	●	●	DN100	242	375	1750	1380 x 430 x 710	85
19990447 (MB... 407)	●		●	●	●	●		●	3/4"	72	160	354	400 x 300 x 280	6
19990448 (MB... 412)	●		●	●	●	●		●	1 1/4"	95	175	500	520 x 410 x 460	9
19990449 (MB... 415)	●		●	●	●	●	●	●	1 1/2"	103	185	643	650 x 500 x 380	12
19990450 (MB... 420)	●		●	●	●	●	●	●	2"	114	225	711	990 x 300 x 500	13
19990451 (MB... 425)	●		●	●	●	●	●	●	2"	114	291	951	990 x 300 x 500	19
19990452 (DMV... 5080)	●		●	●	●	●	●	●	DN80	210	304	1430	1380 x 430 x 710	70
19990453 (DMV... 5100)	●		●	●	●	●	●	●	DN100	242	375	1750	1380 x 430 x 710	85
19990468 (VGD40.065)	●	●	●	●	●	●	●	●	DN65	118	380	1020	1380 x 430 x 710	30
19990469 (VGD40.080)	●	●	●	●	●	●	●	●	DN80	132	387	1150	1380 x 430 x 710	39
19990470 (VGD40.100)	●	●	●	●	●	●	●	●	DN100	145	397	1350	1380 x 430 x 710	50

● - As standard; ▲ - As standard for burners with an output of more than 1200 kW.

Legend

CTV - Valve tightness control	Pmin - Minimum pressure switch	RP - Pneumatic regulator	VPS - VPS valve tightness control
F - Filter	R - Pressure regulator	VF - Regulator throttle valve	VS - Safety valve
LDU - LDU valve tightness control	RF - Pressure regulator with filter	VL - Operating valve	VSP - Safety pilot valve
Pct - Pressure switch for gas control	RFP - Pressure regulator with filter for pilot gas train	VL2 - Two-stage operating valve	Ø - Gas train diameter
Pmax - Maximum pressure switch	RM - Manual flow rate regulator	VLP - Operating pilot valve	Ø1 - Main gas train diameter
Pmc - Minimum and control pressure switch gas leaks		VP - Pilot valve	Ø2 - Pilot gas train diameter

By inserting the RWF40 kit and the modulating kit into the two progressive stage burners, these are transformed into modulating burners, that is, with the capacity to provide thermal power which can be varied continuously in accordance with the specific needs of the boiler. Naturally, the thermal power level varies only within the "minimum" and "maximum" limits applying to the burner.



Selecting modulation kit components

With reference to parameter: temperature (°C) or pressure (bar), select the regulation range corresponding to the operating value of the boiler. When the value falls within two different setting ranges, select the lower of the two.

Example:

If the temperature of the water in the boiler is to be 100°C, choose the modulation kit corresponding to range 0 - 130°C. If the pressure of the steam in the boiler is to be 8 bar, select the modulation kit in the regulation range 0 - 10 bar.

RWF 40 electronic regulator for all modulating burners, used to regulate temperature or pressure.

Automatic proportional modulation regulator

Part no.	Model
98000051	Kit RWF 40
98000052	Kit RWF 40 for BGS 30 LX

Temperature modulation kit

Part no.	Temperature	Type probe	Probe length	Male coupling
98000020	0 °C - 130 °C	NI 1000	100 1)	R 1/2"
98000021	0 °C - 500 °C	PT 1000	200 1)	G 1/2"
98000022	0 °C - 1100 °C	Thermocouple	425 1)	R 1/2"

Steam pressure modulation kit

Part no.	Steam pressure	Male coupling
98000025	0 - 1 bar	G 1/2"
98000026	0 - 10 bar	G 1/2"
98000027	0 - 16 bar	G 1/2"
98000028	0 - 25 bar	G 1/2"
98000029	0 - 40 bar	G 1/2"

Notes

For different modulation values please contact our Technical Assistance Service.
1) Different lengths on request.