



TECHNICAL AND FUNCTIONAL CHARACTERISTICS

- Gas-fired burner.
- Two-stage operation (high/low flame).
- Ability to operate with any type of combustion chamber.
- Air-gas mixing at blast-pipe.
- Ability to obtain optimal combustion values by regulating combustion air and blast-pipe.
- Maintenance facilitated by the fact that the mixing unit can be removed without having to remove the burner from the boiler.
- Air flow regulation for first and second stage by means of electric servomotor with pause closure of gate to prevent any heat dispersion to flue.
- Possibility to chose gas train with valve tightness control.
- Equipped with one flange and one insulating seal for boiler fastening.

CONSTRUCTION CHARACTERISTICS

The burner consists of:

- Light aluminium alloy fan part.
- High performance centrifugal fan.
- Combustion air intake with air flow adjustment device.
- Sliding boiler coupling flange to adapt the head protrusion to the various types of boilers.
- Adjustable blast-pipe with stainless steel nozzle and deflector disk in steel.
- Three-phase electric motor to run fan.
- Air pressure switch to ensure the presence of combustion air.
- Gas train complete with operation and safety valve, minimum pressure switch, pressure regulator and gas filter.
- Automatic control and command equipment for the burner, compliant with European standard EN298.
- Flame detection by ionisation electrode.
- Control panel comprising stop/go switch, 1st/2nd stage selector, operation and block indicator.
- Terminal block for the electrical and thermostatic connections to the burner and to control the second stage of working.
- Electrical protection rating IP40.

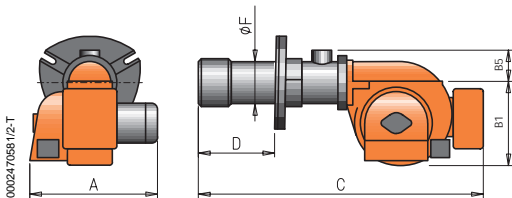

Conforms to:
 Gas Directive 90/396/CEE
 E.M.C. Directive 89/336/CEE
 L.V. Directive 73/23/CEE
 Reference standard: EN676

| Thermal output kW | Model | Part no. | Electrical supply | Motor kW | A mm | B 1 mm | B 5 mm | C mm | D mm | F mm | Size of packaging L x P x H mm | Weight kg | Notes |
|-------------------|---------|----------|-------------------|----------|------|--------|--------|------|-----------|------|--------------------------------|-----------|-------|
| 185 - 425 | BGN 40 | 16060010 | 3N AC 50Hz 400V | 0.37 | 470 | 295 | 102 | 1100 | 150 - 330 | 135 | 1260 x 660 x 680 | 63 | 4) |
| 248 - 738 | BGN 60 | 16510010 | 3N AC 50Hz 400V | 1.1 | 560 | 365 | 120 | 1270 | 170 - 400 | 160 | 1510 x 750 x 720 | 88 | 4) |
| 280 - 995 | BGN 100 | 16560010 | 3N AC 50Hz 400V | 1.1 | 560 | 365 | 120 | 1330 | 240 - 460 | 160 | 1510 x 750 x 720 | 91 | 4) |

Frequency 50 Hz

Accessories available on request

| Part no. | Description |
|----------|--|
| 97980054 | Soundproof burner cover for BGN 40 |
| 97980055 | Soundproof burner cover for BGN 60-100 |

Gas burner accessories

Boiler coupling kit

Notes

- 4) Equipped with automatic device for air closing.
 - 5) Valve tightness control not required by EN676.
 - 6) Where gas pressure at the safety valve is less than 12mbar, replace the minimum pressure switch with a GW50 pressure switch.
- CTV) Gas train with Valve Tightness Control.
- *) Minimum gas train inlet pressure needed to obtain maximum burner power with a combustion chamber backpressure of zero.
- **) Maximum gas pressure at pressure regulator in CE version, at gas train for EXP version.

Net calorific value of natural gas: $H_i = 35.80 \text{ MJ/m}^3 = 8550 \text{ kcal/m}^3$, at reference conditions of 0°C , 1013 mbar.

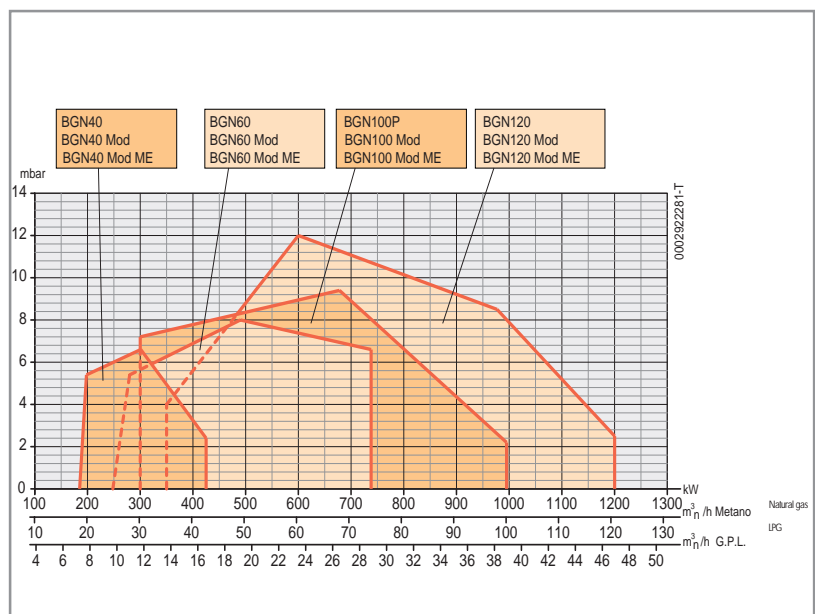

BURNER/GAS TRAIN MATCH - CE gas train version complies with EN676, EXP gas train version is for extra-European markets

| Burner model | Gas type | Version | Curve on graph | Execution | P.Max** mbar | Gas train | | Regulator with incorporated filter | | Burner/gas train adapter | | Pic. | Notes |
|--------------|-------------|----------|----------------|-----------|--------------|-----------|--|------------------------------------|--|--------------------------|--|------|-------|
| | | | | | | Part no. | | Part no. | | Part no. | | | |
| BGN 40 | NATURAL GAS | CE / EXP | 15A | | 360 | 19990411 | | Included | | — | | B2 | |
| | | | 15B | | 360 | 19990410 | | Included | | — | | B2 | |
| | | | 15C | | 360 | 19990404 | | Included | | — | | B2 | |
| | | | | CTV | 360 | 19990454 | | Included | | — | | B2 | 5) |

| Burner model | Gas type | Version | Execution | P.Gas* mbar | Gas train | | Regulator with incorporated filter | | Burner/gas train adapter | | Pic. | Notes |
|--------------|----------|---------|-----------|-------------|-----------|--|------------------------------------|--|--------------------------|--|------|-------|
| | | | | | Part no. | | Part no. | | Part no. | | | |
| BGN 40 | LPG | CE | | 30 | 19990411 | | Included | | — | | B2 | |
| | | | CTV | 30 | 19990436 | | 97390030 | | 96000005 | | B4 | 5) |
| | | EXP | | 30 | 19990411 | | Included | | — | | B2 | |
| | | | CTV | 30 | 19990436 | | — | | 96000005 | | BE4 | |

Please see last page for Gas Train Calculations' Example

Head loss (combustion head + gas train + pressure regulator)

BGN 40 Natural gas CE / EXP

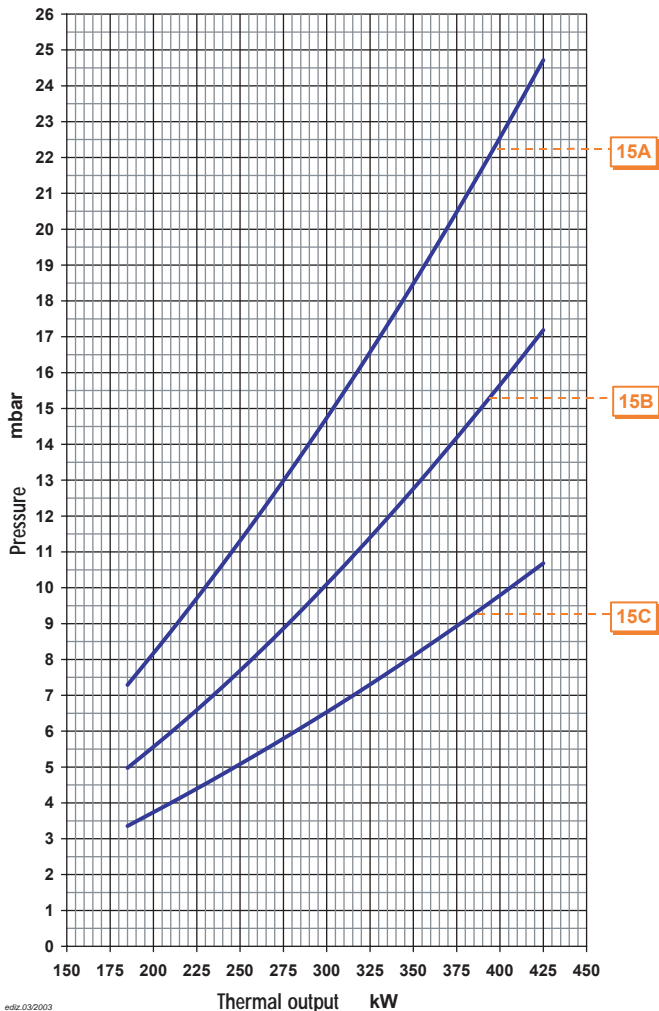

Flange Mounting Dimensions

| L | | M | N |
|-----|-----|-----|-----|
| min | max | | |
| 200 | 245 | M12 | 165 |

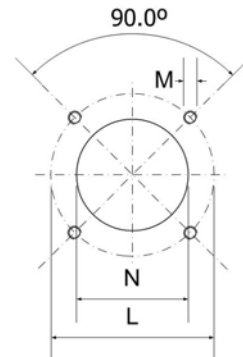

PICTURE B2

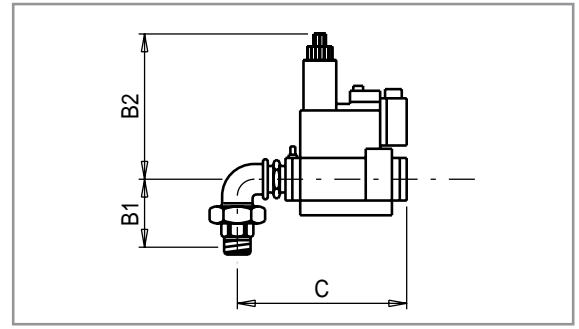
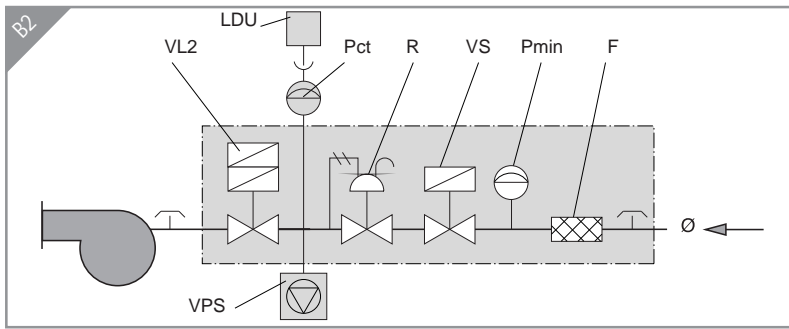

| Gas train part no. | F | LDU | Pct | Pmin | Position | | VPS | VS | Ø | Gas train dimensions | | | Size of packaging mm L x P x H | Weight kg |
|----------------------|---|-----|-----|------|----------|-----|-----|----|---------------------------------|----------------------|-----|-----|--------------------------------------|--------------|
| | | | | | R | VL2 | | | | B1 | B2 | C | | |
| 19990016 (MB... 405) | ● | | | ● | ● | ● | | ● | 3/4" | 72 | 210 | 204 | 310 x 210 x 350 | 5 |
| 19990020 (MB... 407) | ● | | | ● | ● | ● | | ● | 3/4" | 72 | 210 | 204 | 310 x 210 x 350 | 5 |
| 19990024 (MB... 410) | ● | | | ● | ● | ● | | ● | 1 ¹ / ₄ " | 95 | 260 | 249 | 310 x 210 x 350 | 8 |
| 19990168 (MB... 412) | ● | | | ● | ● | ● | | ● | 1 ¹ / ₄ " | 95 | 260 | 249 | 310 x 210 x 350 | 8 |
| 19990404 (MB... 415) | ● | | | ● | ● | ● | | ● | 1 ¹ / ₂ " | 103 | 270 | 311 | 520 x 410 x 460 | 11 |
| 19990405 (MB... 420) | ● | | | ● | ● | ● | | ● | 2" | 114 | 330 | 367 | 520 x 410 x 460 | 13 |
| 19990410 (MB... 412) | ● | | | ● | ● | ● | | ● | 1 ¹ / ₄ " | 103 | 260 | 255 | 520 x 410 x 460 | 9 |
| 19990411 (MB... 410) | ● | | | ● | ● | ● | | ● | 1 ¹ / ₄ " | 103 | 260 | 255 | 520 x 410 x 460 | 9 |
| 19990454 (MB... 415) | ● | ● | ● | ● | ● | ● | | ● | 1 ¹ / ₂ " | 103 | 270 | 311 | 520 x 410 x 460 | 12 |
| 19990455 (MB... 420) | ● | ● | ● | ● | ● | ● | | ● | 2" | 114 | 330 | 367 | 520 x 410 x 460 | 14 |

PICTURE B4

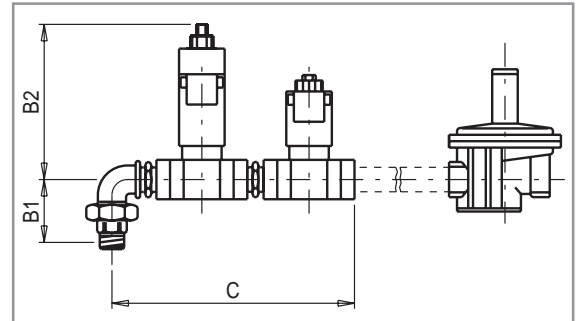
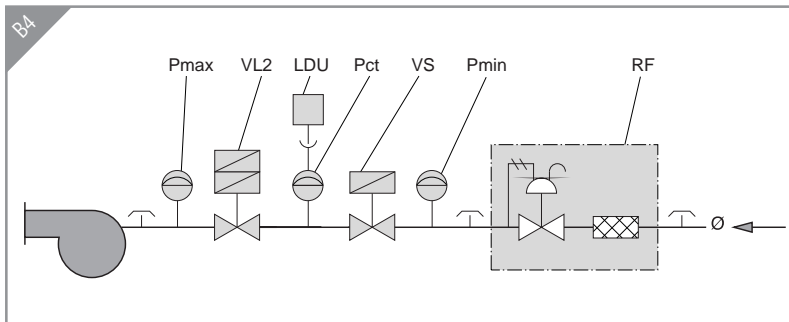

| Gas train part no. | LDU | Pct | Pmax | Position | | VL2 | VS | Ø | Gas train dimensions | | | Size of packaging mm L x P x H | Weight kg |
|--------------------|-----|-----|------|----------|---------------------------------|------|------|---------------------------------|----------------------|-----|-----|--------------------------------------|--------------|
| | | | | Pmin | RF | | | | B1 | B2 | C | | |
| 19990436 | ● | ● | ● | ● | 1" | 3/4" | 3/4" | 1" | 72 | 235 | 256 | 520 x 410 x 460 | 11 |
| 19990438 | ● | ● | ● | ● | 1 ¹ / ₂ " | 1" | 1" | 1 ¹ / ₂ " | 83 | 235 | 296 | 520 x 410 x 460 | 13 |
| 19990456 | | | ● | ● | DN65 | 2" | 2" | DN65 | 114 | 305 | 454 | 520 x 410 x 460 | 20 |
| 19990457 | ● | ● | ● | ● | DN65 | 2" | 2" | DN65 | 114 | 305 | 454 | 520 x 410 x 460 | 21 |
| 19990458 | | | ● | ● | DN65 | 2" | DN65 | DN65 | 114 | 305 | 682 | 830 x 430 x 620 | 36 |
| 19990459 | ● | ● | ● | ● | DN65 | 2" | DN65 | DN65 | 114 | 305 | 682 | 830 x 430 x 620 | 37 |

Legend

| | | | |
|---|--|---------------------------------|-----------------------------------|
| CTV - Valve tightness control | Pmin - Minimum pressure switch | RP - Pneumatic regulator | VPS - VPS valve tightness control |
| F - Filter | R - Pressure regulator | VF - Regulator throttle valve | VS - Safety valve |
| LDU - LDU valve tightness control | RF - Pressure regulator with filter | VL - Operating valve | VSP - Safety pilot valve |
| Pct - Pressure switch for gas control | RFP - Pressure regulator with filter for pilot gas train | VL2 - Two-stage operating valve | Ø - Gas train diameter |
| Pmax - Maximum pressure switch | RM - Manual flow rate regulator | VLP - Operating pilot valve | Ø1 - Main gas train diameter |
| Pmc - Minimum and control pressure switch gas leaks | | VP - Pilot valve | Ø2 - Pilot gas train diameter |

PICTURE BE4

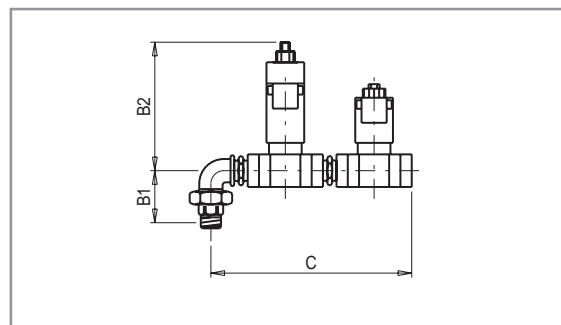
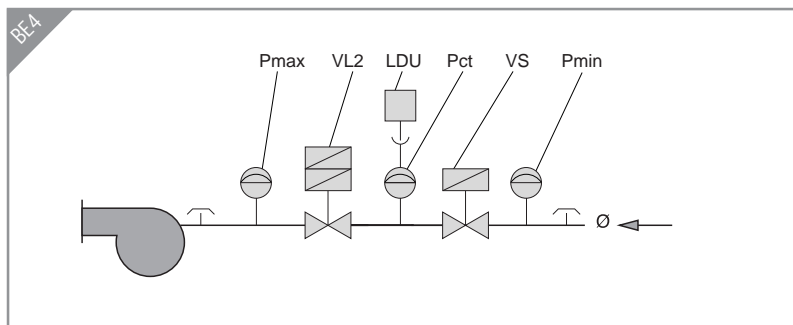

| Gas train part no. | Gas train components | | | | | | | Gas train dimensions mm | | | Size of packaging mm L x P x H | Weight kg |
|--------------------|----------------------|-----|------|---------------|------|------|------|-------------------------|-----|-----|-----------------------------------|-----------|
| | LDU | Pct | Pmax | Position Pmin | VL2 | VS | Ø | B1 | B2 | C | | |
| 19990436 | ● | ● | ● | ● | 3/4" | 3/4" | 3/4" | 72 | 235 | 256 | 520 x 410 x 460 | 11 |
| 19990438 | ● | ● | ● | ● | 1" | 1" | 1" | 83 | 235 | 296 | 520 x 410 x 460 | 13 |
| 19990456 | | | ● | ● | 2" | 2" | 2" | 114 | 305 | 454 | 520 x 410 x 460 | 20 |
| 19990457 | ● | ● | ● | ● | 2" | 2" | 2" | 114 | 305 | 454 | 520 x 410 x 460 | 21 |
| 19990458 | | | ● | ● | 2" | DN65 | DN65 | 114 | 305 | 682 | 830 x 430 x 620 | 36 |
| 19990459 | ● | ● | ● | ● | 2" | DN65 | DN65 | 114 | 305 | 682 | 830 x 430 x 620 | 37 |

Legend

| | | | |
|---|--|---------------------------------|-----------------------------------|
| CTV - Valve tightness control | Pmin - Minimum pressure switch | RP - Pneumatic regulator | VPS - VPS valve tightness control |
| F - Filter | R - Pressure regulator | VF - Regulator throttle valve | VS - Safety valve |
| LDU - LDU valve tightness control | RF - Pressure regulator with filter | VL - Operating valve | VSP - Safety pilot valve |
| Pct - Pressure switch for gas control | RFP - Pressure regulator with filter for pilot gas train | VL2 - Two-stage operating valve | Ø - Gas train diameter |
| Pmax - Maximum pressure switch | RM - Manual flow rate regulator | VLP - Operating pilot valve | Ø1 - Main gas train diameter |
| Pmc - Minimum and control pressure switch gas leaks | | VP - Pilot valve | Ø2 - Pilot gas train diameter |

Using the specific diagrams, it is possible to select the gas train that is most suitable for the burner.

First of all it is necessary to identify:

- Burner's heat input Q_i [kW], to be identified along the x-coordinate.
- Gas pressure available at the regulator P_g [mbar], to be identified along the y-coordinate.

The available gas pressure is determined by the formula: $P_g = P_a - P_c$

where:

- P_a = gas pressure provided by the mains supply;
- P_c = the pressure in the boiler combustion chamber.

The intersection point of the two lines defines the operational parameters of the gas train.

The gas train characterised by the first curve underneath the intersection point must be chosen.

EXAMPLE

- Burner = BGN 200P
 - $Q_i = 1700$ kW
 - $P_a = 44.5$ mbar
 - $P_c = 2.5$ mbar
 - $P_g = 44.5 - 2.5 = 42$ mbar
- Choose the indicated curve 20C.

The red segment of the curve indicates that the neutral-coloured spring of the regulator must be replaced with the red one (supplied).

To identify the codes for the gas train, pressure regulator and adapter to be ordered refer to the BURNER/TRAIN MATCH-UP TABLE relative to burner BGN200P and CURVE REFERENCE 20C.

Note:

In the graphs the head loss curves have different colours.

The mono-colour BLUE curve represents a gas train with a monoblock valve. The mono-colour ORANGE curve represents a gas train with a mono-valve or with separate valves without pressure regulator; this execution does not comply with EN676 regulation.

The multi-colour curve represents a gas train with separate valves and pressure regulator (this version complies with EN676 regulation). The coloured segments identify the colour of the spring with which the regulator should be used under those specific flow rate/pressure conditions. The pressure regulator is supplied with different-coloured springs (green, red and violet): these are used to replace the one already installed (neutral colour) at the time of installation if necessary.

