



TECHNICAL AND FUNCTIONAL CHARACTERISTICS

- Light oil burner.
- Single stage operation (on/off).
- Ability to operate with any type of combustion chamber.
- High pressure mechanical atomisation of fuel using nozzle.
- Ability to obtain optimal combustion values by regulating combustion air and blast-pipe.
- Maintenance facilitated by the fact that the atomisation unit can be removed without having to remove the burner from the boiler.
- Manual air flow adjustment.
- When using biodiesel light oil (fuel of vegetable origin), the burner must be built with specific components: flexible hoses, line filter and pump.
- Equipped with one 7 pole connector, one flange and one insulating seal for boiler fastening, 2 flexible hoses, one line filter and one nozzle.
- On request: longer blast tube, operation on biodiesel.

CONSTRUCTION CHARACTERISTICS

The burner consists of:

- Light aluminium alloy fan part.
- High performance centrifugal fan.
- Combustion air inlet with device to adjust the air flow; automatically closing air gate.
- Sliding coupling flange to adapt the head protrusion to the various types of boilers (with the exception of BTL 3, BTL 3H).
- Adjustable combustion head complete with steel blast tube and deflector disk.
- Monophase electric motor to run fan and pump.
- Gear pump with pressure regulator and fuel stop-cock valve.
- Variable output fuel preheater (H version).
- Automatic control and command equipment for the burner compliant with European standard EN230.
- Flame detection by photoresistance.
- 7 pole outlet for burner electrical and thermostat supply.
- Electrical protection rating IP40.
- Sound-proof plastic protective cover.

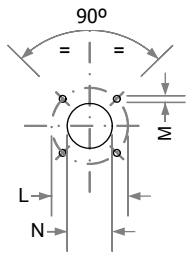
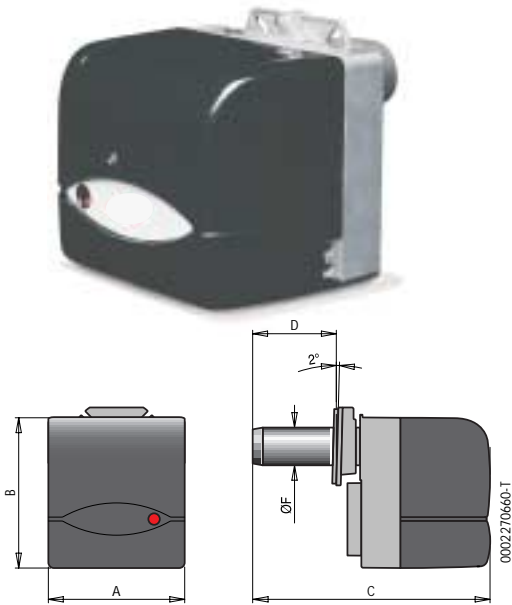

Flange Mounting Dimensions

L		M	N
min	max		
130	155	M8	85

Conforms to:
 E.M.C. Directive 89/336/CEE
 L.V. Directive 73/23/CEE
 Reference standard: EN267

Thermal output kW	Model	Part no.	Max visc. °E at 20°C	Electrical supply	Motor kW	A mm	B mm	C mm	D mm	F mm	Size of packaging L x P x H mm	Weight kg	Notes
21.3 - 42.7	BTL 0	35470010	1.5	1N AC 50Hz 230V	0.11	245	270	410	50 - 105	80	540 x 300 x 320	12	1)

Optionals

Description

200 mm long combustion head for BTL 0-3

Biodiesel operation

Light oil burner accessories

Line filter - Flex hoses - Nozzle - Boiler coupling kit - 7 pin plug

Notes

Equipped with air closure device.

Net calorific value of light oil: Hi = 42.70 MJ/kg = 10200 kcal/kg.

