



TECHNICAL AND FUNCTIONAL CHARACTERISTICS

- Light oil burner.
- Single stage operation (on/off).
- Ability to operate with any type of combustion chamber.
- High pressure mechanical atomisation of fuel using nozzle.
- Ability to obtain optimal combustion values by regulating combustion air and blast-pipe.
- Maintenance facilitated by the fact that the atomisation unit can be removed without having to remove the burner from the boiler.
- Manual air flow adjustment.
- When using biodiesel light oil (fuel of vegetable origin), the burner must be built with specific components: flexible hoses, line filter and pump.
- Equipped with one 7 pole connector, one flange and one insulating seal for boiler fastening, 2 flexible hoses, one line filter and one nozzle.
- On request: operation on biodiesel.

CONSTRUCTION CHARACTERISTICS

The burner consists of:

- Light aluminium alloy fan part.
- High performance centrifugal fan.
- Combustion air inlet with device to adjust the air flow; automatically closing air gate (except BTL 26).
- Sliding coupling flange to adapt the head protrusion to the various types of boilers.
- Adjustable blast-pipe with stainless steel nozzle and deflector disk in steel.
- Monophase electric motor to run fan and pump.
- Gear pump with pressure regulator and fuel stop-cock valve.
- Automatic control and command equipment for the burner compliant with European standard EN230.
- Flame detection by photoresistance.
- 7 pole outlet for burner electrical and thermostat supply.
- Electrical protection rating IP40.
- Sound-proof plastic protective cover.

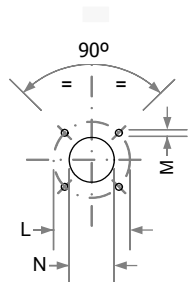
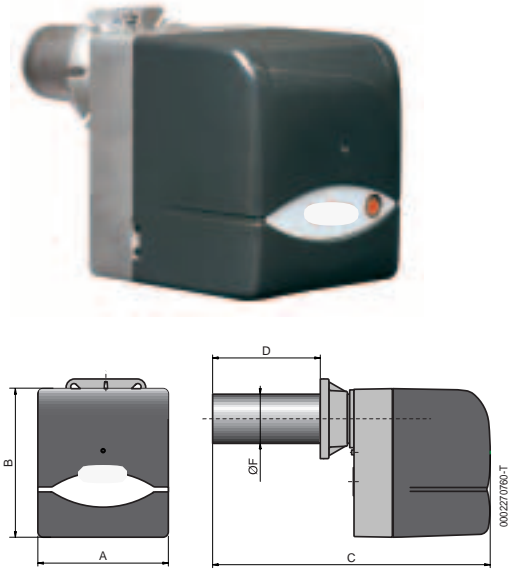

Flange Mounting Dimensions

L		M	N
min	max		
150	200	M10	110

Conforms to:
 E.M.C. Directive 89/336/CEE
 L.V. Directive 73/23/CEE
 Reference standard: EN267

Thermal output kW	Model	Part no.	Max Visc. °E at 20°C	Electrical supply	Motor kW	A mm	B mm	C mm	D mm	F mm	Size of packaging L x P x H mm	Weight kg	Notes
83 - 166	BTL 14	35610010	1.5	1N AC 50Hz 230V	0.18	303	345	645	100 - 250	100	750 x 370 x 410	18	1)

Frequency 50 Hz

Optionals

Description
Biodiesel operation

Light oil burner accessories

Line filter - Flex hoses - Nozzle - Boiler coupling kit - 7 pin plug
--

Notes

- 1) Equipped with air closure device.
 Net calorific value of light oil: Hi = 42.70 MJ/kg = 10200 kcal/kg.

