



### TECHNICAL AND FUNCTIONAL CHARACTERISTICS

- Low NOx and CO emissions light oil burner compliant with European standard EN267 "Classe III".
- Two-stage operation (high/low flame).
- Suitable for working in combustion chambers different than reverse flame.
- High pressure mechanical atomisation of fuel using nozzle.
- Combustion head (recycling of combusted gas for RiNOx 60L2) able to achieve very low pollutant emissions, particularly with regard to nitrous oxides (NOx).
- Maintenance facilitated by the fact that the atomisation unit can be removed without having to remove the burner from the boiler.
- Air flow regulation for first and second stage by means of electric servomotor with pause closure of gate to prevent any heat dispersion to flue.
- Equipped with one 4 and 7 pole connector, one flange and one insulating seal for boiler fastening, 2 flexible hoses, one line filter and one nozzle.

### CONSTRUCTION CHARACTERISTICS

The burner consists of:

- Light aluminium alloy fan part.
- High performance centrifugal fan.
- Combustion air inlet with device to adjust the air flow; automatically closing air gate.
- Sliding boiler coupling flange to adapt the head protrusion to the various types of boilers.
- Adjustable combustion head with blast pipe (inox steel for RiNOx 60 L2) and steel flame disk.
- Monophase electric motor to run fan and pump.
- Gear pump with pressure regulator and fuel stop-cock valves.
- Automatic control and command equipment for the burner compliant with European standard EN230.
- Flame detection by photoresistance.
- 7 pole outlet for burner electrical and thermostat connections, and 4 pole outlet for second stage control.
- Electrical protection rating IP40.
- Sound-proof plastic protective cover.

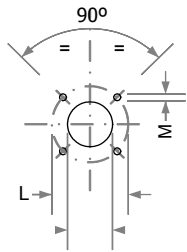
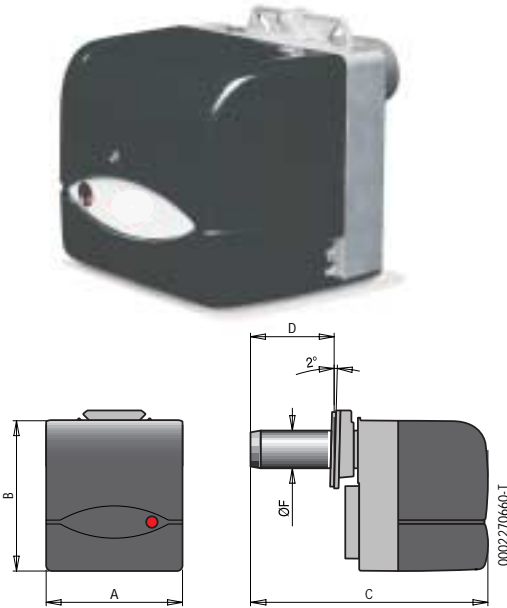

Flange Mounting Dimensions

L		M	N
min	max		
160	155	M8	95

Conforms to:  
 E.M.C. Directive 89/336/CEE  
 L.V. Directive 73/23/CEE  
 Reference standard: EN267

Thermal output kW	Model	Part no.	Max visc. °E at 20°C	Electrical supply	Motor kW	A mm	B mm	C mm	D mm	F mm	Size of packaging L x P x H mm	Weight kg	Notes
38 - 74	RiNOx 60	35520050	1.5	1N AC 50Hz 230V	0.11	245	270	455	50 - 150	90	540 x 300 x 320	12	1)

Frequency 50 Hz

### Light oil burner accessories

Line filter - Flex hoses - Nozzle - Boiler coupling kit - 4 and 7 pin plug

### Notes

- 1) Equipped with air closure device.  
 Net calorific value of light oil: Hi = 42.70 MJ/kg = 10200 kcal/kg.

