

KEY TO DIAGRAM

A1	-	DUNGS MPA CONTROL
F1	-	THERMAL RELAY
H1	-	OPERATION LAMP
H2	-	LOCKOUT LAMP
K1	-	MOTOR CONTACTOR
MV	-	MOTOR
S1	-	ON-OFF SWITCH
S4	-	AUTO-MAN SWITCH
S5	-	MIN-MAX SWITCH
S24	-	START-STOP SWITCH
TA	-	IGNITION TRANSFORMER
TC	-	CONTROL STAT
TS	-	SAFETY STAT
X1.	-	BURNER TERMINAL RAIL
YP	-	MAIN GAS VALVE
YS	-	SAFETY GAS VALVE
X2	-	7-POLE CONNECTOR
X3	-	4-POLE CONNECTOR
PM	-	MAX GAS ORESSURE SWITCH
H3	-	REMOTE LOCKOUT LAMP
H4	-	REMOTE OPERATION LAMP

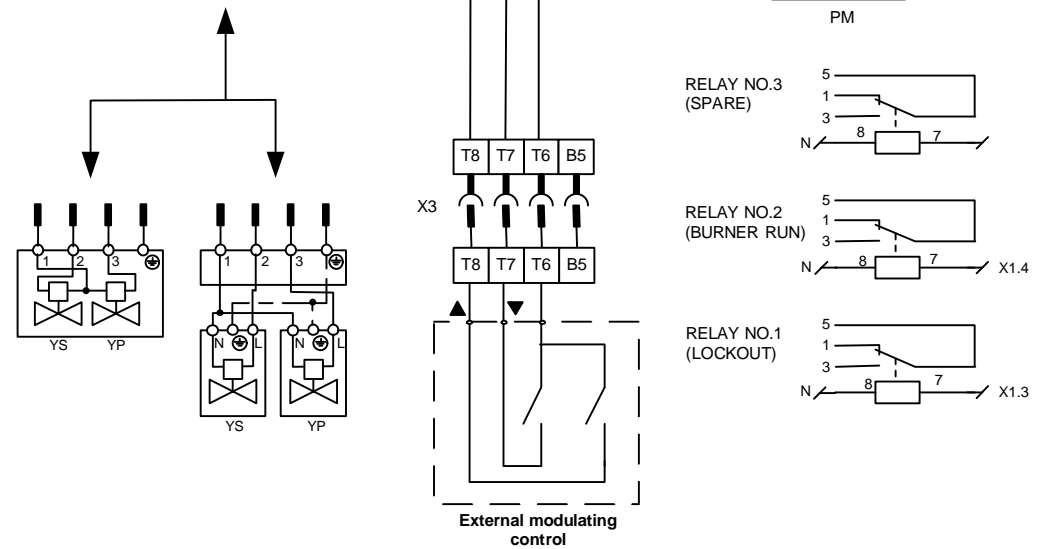
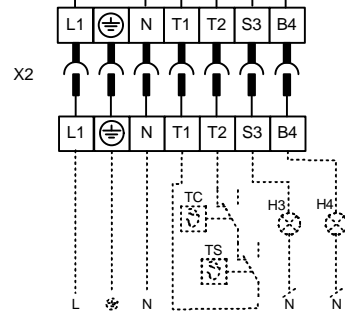

External modulating control