

CE



- Instruction for light oil burner models

RiNOx 35



Edition

2006/05

- Warning Notes for the User -----	3
- Technical Specifications -----	5
- Hydraulic Connections -----	8
- Application of the Burner to the Boiler -----	9
- Burner Specifications -----	10
- Ignition Adjustment - Air Regulation Principle Diagram - Combustion Adjustment-----	11
- Maintenance-----	12
- Pump Specifications -----	13
- Fault Finding Table -----	14
- Electric Diagram-----	15
- Nozzle Flow Rate -----	16

We hereby declare that our gas, light oil, heavy oil, and combination (gas/light oil or gas/heavy oil) burners are manufactured in conformance with current CE, CEI and UNI standards.

- EOGB guarantees the “CE” certification provided that the burner is coupled to the “CE” gas train supplied by EOGB and the “CE” gas line accessories (on request).

**NOTE:** this declaration is not valid with regard to EC or U NI Standards for gas burners or the gas part of dual-fuel burners (gas/light oil or gas/heavy oil) when such burners have been ordered in non-compliance with the EC Standard or Italian UN I Standard because they are to be used for special purposes not provided for in the above mentioned standards.

Before using the burner for the first time please carefully read the chapter “WARNINGS NOTES FOR THE USER: HOW TO USE THE BURNER SAFELY” in this instruction manual, which is an integral and essential part of the product. The works on the burner and on the system have to be carried out only by competent people.

- Read carefully the instructions before starting the burner and service it.
- The electric supply must be disconnected before starting working on it.
- If the works are not carried out correctly it is possible to cause dangerous accidents.

# WARNING NOTES FOR THE USER

## HOW TO USE THE BURNER SAFELY

### FOREWORD

These warning notes are aimed at ensuring the safe use of the components of heating systems for civil use and the production of hot water. They indicate how to act to avoid the essential safety of the components being compromised by incorrect or erroneous installation and by improper or unreasonable use. The warning notes provided in this guide also seek to make the consumer more aware of safety problems in general, using necessarily technical but easily understood language. The manufacturer is not liable contractually or extra contractually for any damage caused by errors in installation and in use, or where there has been any failure to follow the manufacturer's instructions.

### GENERAL WARNING NOTES

- The instruction booklet is an integral and essential part of the product and must be given to the user. Carefully read the warnings in the booklet as they contain important information regarding safe installation, use and maintenance. Keep the booklet to hand for consultation when needed.
- Equipment must be installed in accordance with current regulations, with the manufacturer's instructions and by qualified technicians. By the term 'qualified technicians' is meant persons that are competent in the field of heating components for civil use and for the production of hot water and, in particular, assistance centres authorised by the manufacturer. Incorrect installation may cause damage or injury to persons, animals or things. The manufacturer will not in such cases be liable.
- After removing all the packaging make sure the contents are complete and intact. If in doubt do not use the equipment and return it to the supplier. The packaging materials (wooden crates, nails, staples, plastic bags, expanded polystyrene, etc.) must not be left within reach of children as they may be dangerous to them. They should also be collected and disposed on in suitably prepared places so that they do not pollute the environment.
- Before carrying out any cleaning or maintenance, switch off the equipment at the mains supply, using the system's switch or shut-off systems.
- If there is any fault or if the equipment is not working properly, de-activate the equipment and do not attempt to repair it or tamper with it directly. In such case get in touch with only qualified technicians. Any product repairs must only be carried out by EOGB authorised assistance centres using only original spare parts. Failure to act as above may jeopardise the safety of the equipment. To ensure the efficiency and correct working of the equipment, it is essential to have periodic maintenance carried out by qualified technicians following the manufacturer's instructions.
- If the equipment is sold or transferred to another owner or if the owner moves and leaves the equipment, make sure that the booklet always goes with the equipment so it can be consulted by the new owner and/or installer.
- For all equipment, with optionals or kits (including electrical), only original accessories must be used.

### BURNERS

- This equipment must be used only for its expressly stated use: applied to boilers, hot air boilers, ovens or other similar equipment and not exposed to atmospheric agents. Any other use must be regarded as improper use and hence dangerous.
- The burner must be installed in a suitable room that has ventilation in accordance with current regulations and in any case sufficient to ensure correct combustion
- Do not obstruct or reduce the size of the burner' air intake grills or the ventilation openings for the room where a burner or a boiler is installed or dangerous mixtures of toxic and explosive gases may form.
- Before connecting the burner check that the details on the plate correspond to those of the utility supplies (electricity, gas, light oil or other fuel).
- Do not touch hot parts of the burner. These, normally in the areas near to the flame and any fuel pre-heating system, become hot when the equipment is working and stay hot for some time after the burner has stopped.
- If it is decided not to use the burner any more, the following actions must be performed by qualified technicians:
  - a) Switch off the electrical supply by disconnecting the power cable from the master switch.
  - b) Cut off the fuel supply using the shut-off valve and remove the control wheels from their position.
  - c) Render harmless any potentially dangerous parts.

#### Special warning notes

- Check that the person who carried out the installation of the burner fixed it securely to the heat generator so that the flame is generated inside the combustion chamber of the generator itself.
- Before starting up the burner, and at least once a year, have qualified technicians perform the following operations:
  - a) Set the burner fuel capacity to the power required by the heat generator.
  - b) Adjust the combustion air flow to obtain combustion yield of at least the minimum set by current regulations.
  - c) Carry out a check on combustion to ensure the production of noxious or polluting un-burnt gases does not exceed limits permitted by current regulations.
  - d) Check the adjustment and safety devices are working properly.
  - e) Check the efficiency of the combustion products exhaust duct.
  - f) Check at the end of the adjustments that all the adjustment devices mechanical securing systems are properly tightened.
  - g) Make sure that the use and maintenance manual for the burner is in the boiler room.
- If the burner repeatedly stops in lock-out, do not keep trying to manually reset it, but call a qualified technicians to sort out the problem.
- The running and maintenance of the equipment must only be carried out by qualified technicians, in compliance with current regulations.

# WARNING NOTES FOR THE USER

## HOW TO USE THE BURNER SAFELY

### ELECTRICAL SUPPLY

- The equipment is electrically safe only when it is correctly connected to an efficient ground connection carried out in accordance with current safety regulations. It is necessary to check this essential safety requirement. If in doubt, call for a careful electrical check by a qualified technicians, since the manufacturer will not be liable for any damage caused by a poor ground connection.
- Have qualified technicians check that the wiring is suitable for the maximum power absorption of the equipment, as indicated in the technical plate, making sure in particular that the diameter of cables is sufficient for the equipment's power absorption.
- Adapters, multiple plugs and extension cables may not be used for the equipment's power supply.
- An omnipolar switch in accordance with current safety regulations is required for the mains supply connection.
- The electrical supply to the burner must have neutral to ground connection. If the ionisation current has control with neutral not to ground it is essential to make a connection between terminal 2(neutral) and the ground for the RC circuit.
- The use of any components that use electricity means that certain fundamental rules have to followed, including the following: -  
do not touch the equipment with parts of the body that are wet or damp or with damp feet  
- do not pull on electrical cables  
- do not leave the equipment exposed to atmospheric agents (such as rain or sun etc.) unless there is express provision for this. - do not allow the equipment to be used by children or inexperienced persons.
- The power supply cable for the equipment not must be replaced by the user. If the cable gets damaged, switch off the equipment, and call only on qualified technicians for its replacement.
- If you decide not to use the equipment for a while it is advisable to switch off the electrical power supply to all components in the system that use electricity (pumps, burner, etc.).

### GAS, LIGHT OIL, OR OTHER FUEL SUPPLIES

#### General warning notes

- Installation of the burner must be carried out by qualified technicians and in compliance with current law and regulations, since incorrect installation may cause damage to person, animals or things, for which damage the manufacturer cannot be held responsible.
- Before installation it is advisable to carry out careful internal cleaning of all tubing for the fuel feed system to remove any residues that could jeopardise the proper working of the burner.
- For first startup of the equipment have qualified technicians carryout the following checks:
- If you decide not to use the burner for a while, close the tap or taps that supply the fuel.

#### Special warning notes when using gas

- Have qualified technicians check the following:
  - a) that the feed line and the train comply with current law and regulations.
  - b) that all the gas connections are properly sealed.
- Do not use the gas pipes to ground electrical equipment.
- Do not leave the equipment on when it is not in use and always close the gas tap.
- If the user of is away for some time, close the main gas feed tap to the burner.
- If you smell gas:
  - a) do use any electrical switches, the telephone or any other object that could produce a spark;
  - b) immediately open doors and windows to create a current of air that will purify the room;
  - c) close the gas taps;
  - d) ask for the help of qualified technicians.
- Do not block ventilation openings in the room where there is gas equipment or dangerous situations may arise with the build up of toxic and explosive mixtures.

### FLUES FOR HIGH EFFICIENCY BOILERS AND SIMILAR

It should be pointed out that high efficiency boilers and similar discharge combustion products (fumes) at relatively low temperatures into the flue. In the above situation, traditional flues (in terms of their diameter and heat insulation) may be suitable because the significant cooling of the combustion products in these permits temperatures to fall even below the condensation point. In a flue that works with condensation there is soot at the point the exhaust reaches the atmosphere when burning light oil or heavy oil or the presence of condensate water along the flue itself when gas is being burnt (methane, LPG, etc.). Flues connected to high efficiency boilers and similar must therefore be of a size (section and heat insulation) for the specific use to avoid such problems as those described above.

## TECHNICAL SPECIFICATIONS

<b>RiNOx 35</b>		
<b>Burner Output</b>	<b>Max kg/h</b>	<b>3.40</b>
	<b>Min kg/h</b>	<b>1.60</b>
<b>Thermic Capacity</b>	<b>Max kg/h</b>	<b>40.0</b>
	<b>Min kg/h</b>	<b>19.0</b>
<b>Fuel Maximum Viscosity (light oil)</b>	<b>5.5 cst / 20°C</b>	
<b>Electrical Supply</b>	<b>1 ~ 230V ± 10% 50Hz</b>	
<b>Motor</b>	<b>kW</b>	<b>0.11</b>
<b>Pre-heater</b>	<b>W</b>	<b>60</b>
<b>Transformer</b>	<b>30 mA – 2x10kV</b>	
<b>Absorbed Electrical Power *</b>	<b>kW</b>	<b>0.260</b>
<b>Weight</b>	<b>Kg</b>	<b>12</b>
<b>Operations</b>	<b>ON/OFF</b>	

\* Total absorption at start with ignition transformer on.

<b>STANDARD ACCESSORIES</b>	<b>RiNOx 35</b>
<b>Isolating Gasket</b>	N 1
<b>Screws</b>	N 4 M8x40
<b>Screws</b>	N 1 M8x25
<b>Flat Washers</b>	N 4 – Ø8
<b>Flexible Pipes</b>	N 2 1/4"x3/8" x 1200
<b>Nipples</b>	N 2 3/8"
<b>Line Filter</b>	3/8"

## TECHNICAL SPECIFICATIONS

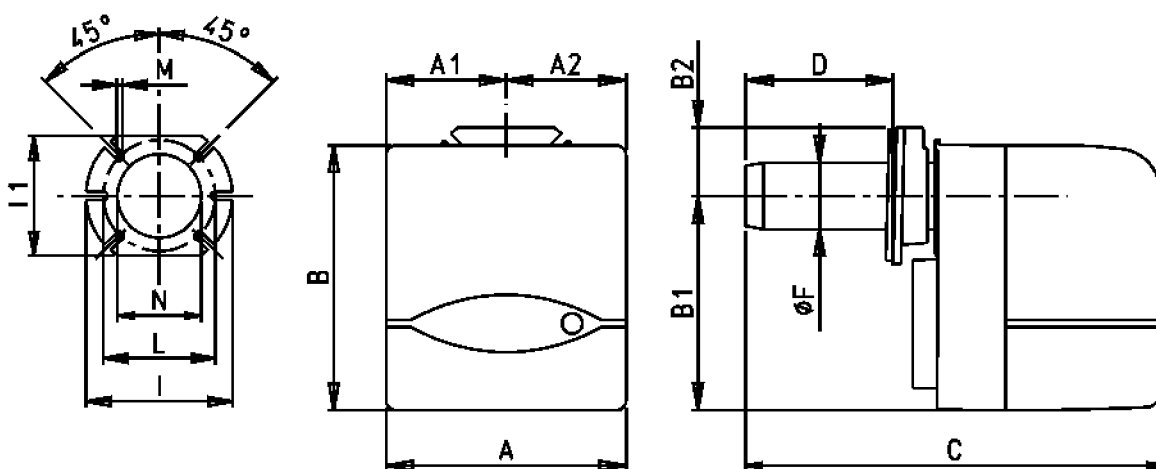
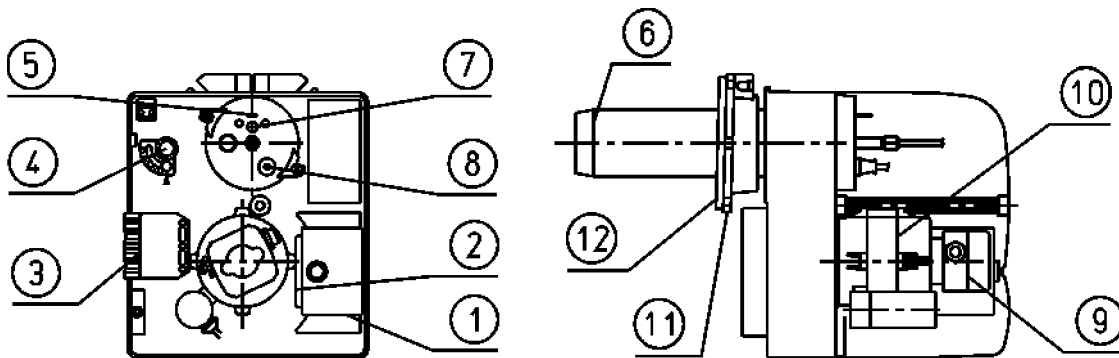

	OVERAL DIMENSIONS															
	A	A1	A2	B	B1	B2	C	D		F	I	I1	L		M	N
								MIN	MAX				MIN	MAX		
<b>RiNOx 35</b>	245	122.5	122.5	220	218.5	70	410	50	105	80	170	140	130	155	M8	85

1. Control Box
2. Transformer
3. 7 Pole Connector
4. Air-Damper Adjusting Screw
5. Reference for Disk Head Positioning
6. Combustion Head
7. Disk Head Adjusting Screw
8. Photocell
9. Electrovalve
10. Light Oil Pump
11. Motor
12. Burner Connection Flange
13. Insulating Gasket

# WORKING FIELD

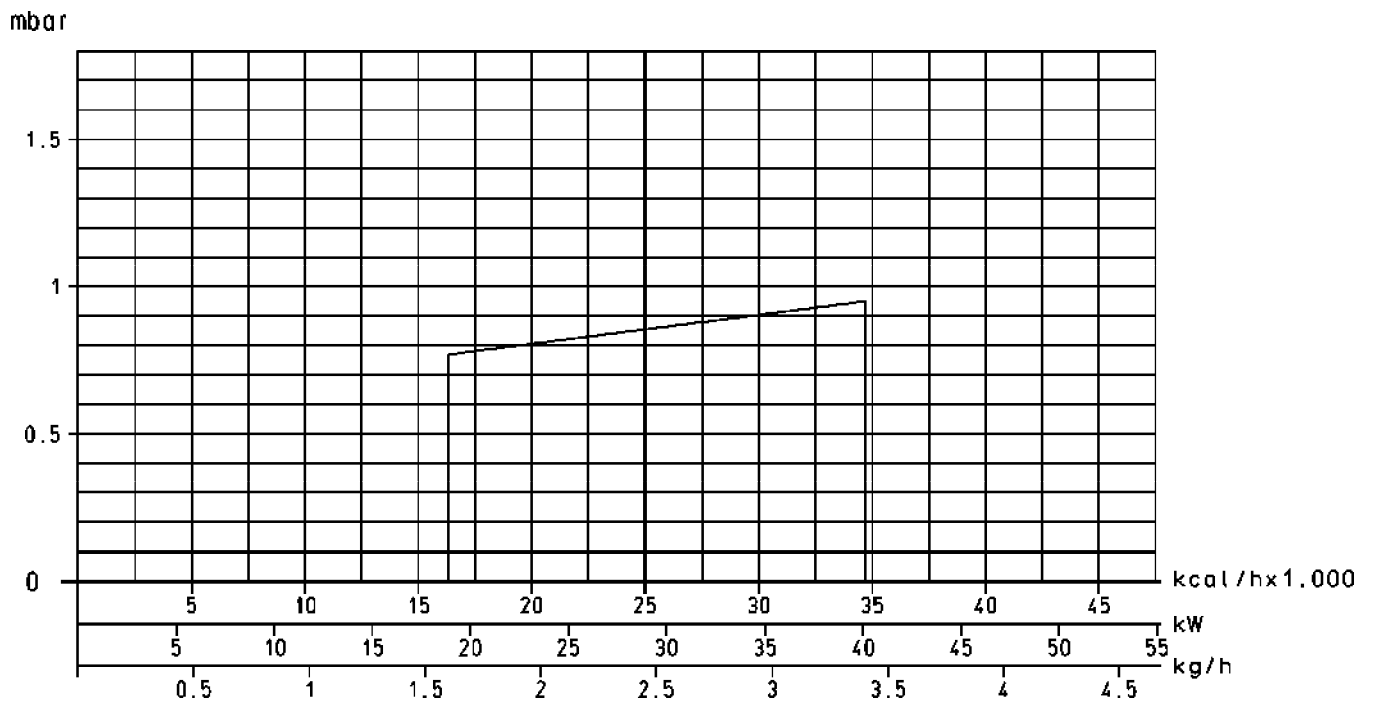

## HYDRAULIC CONNECTIONS

The pipes that connect the tank to the burner should be in perfect tight condition; we recommend the use of copper or steel pipes of an adequate diameter. Fuel gate valves should be fitted at the end of the rigid pipelines. Fit the filter to the suction pipeline after the gate valve. Connect the flexible fitting to this, which in turn should be connected to the suction of the burner pump. Connect the flexible fitting to the return pipe after the gate valve, and then connect it to the pump return. Filter, flexible pipes and relative connection nipples are standard burner accessories. The pump is provided with special connection points for the insertion of control instruments (manometer and vacuum-meter). To ensure reliable and silent operating conditions, the vacuum in suction should not exceed 35 cm Hg equal to 0.46 bar. Maximum suction and return pressure of 1.5 bar.

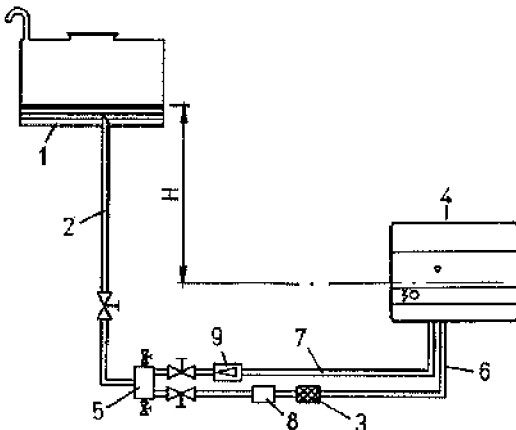

### GRAVITY FEED FROM THE BOTTOM OF OIL TANK

1 Oil tank	6 Suction line
2 Feed line	7 Return line
3 Filter	8 Fire valve
4 Burner	9 Non return valve
5 Degasifier	

H meters	Total meters	
	Ø i. 10 mm.	
1	30	
2	35	
3	40	
4	45	

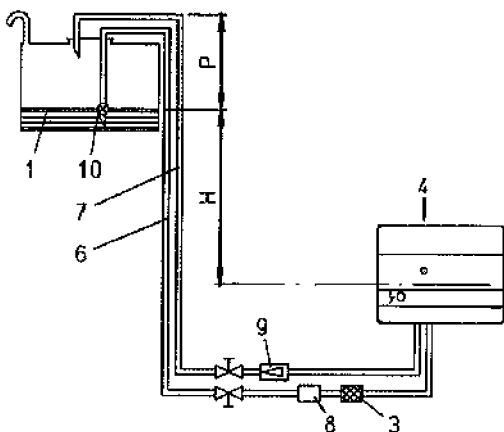

### GRAVITY FEED OVER THE TOP OF OIL TANK

1 Oil tank	7 Return line
3 Filter	8 Fire valve
4 Burner	9 Non return valve
6 Suction line	10 Foot valve

H meters	Total meters	
	Ø i. 10 mm.	
1	30	
2	35	
3	40	
4	45	

Quote P = 3.5 m (max)

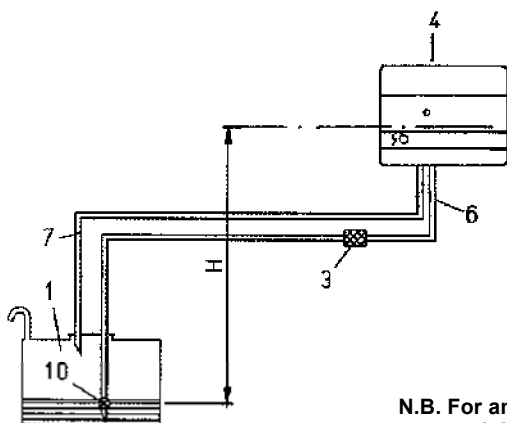

### SUCTION FEED

1 Oil tank	6 Suction line
3 Filter	7 Return line
4 Burner	10 Foot valve

H meters	Total meters	
	Ø i. 10 mm.	Ø i. 12 mm.
0.5	26	54
1	24	47
1.5	18	38
2	14	30
2.5	10	23
3	6	15
3.5	-	7

**N.B. For any missing devices in the piping, conform to existing regulations.**

H = Measurement between minimum oil level and pump axis  
 L = Max. length of suction line, including vertical lifts. For each bend of valve deduct 0.25 m.  
 Ø i = Internal diameter of pipe



## DIAGRAM SHOWING HOW TO PLACE THE FLEXIBLE PIPES

MOTORE AACO

MOTORE SIMEL

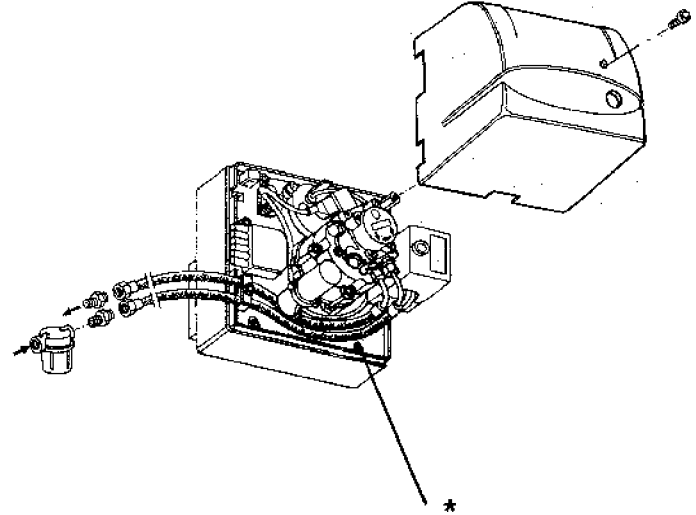
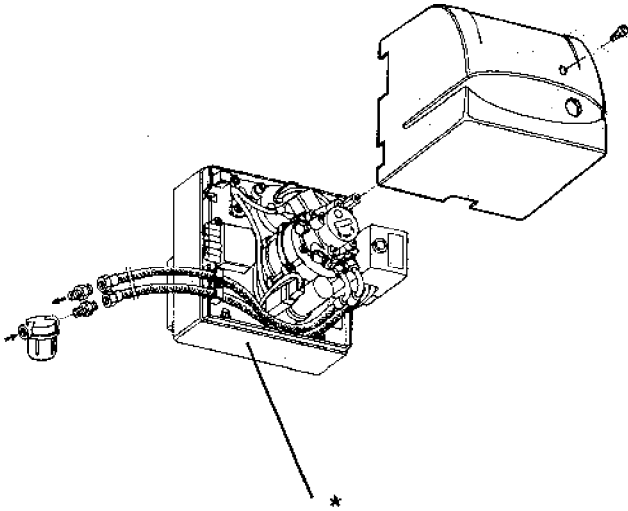

\* The two flexible hoses must be positioned as shown on the figure to ensure correct closing of the cover, they can come out from the lower side or the left side of the burner.

---

## APPLICATION OF THE BURNER TO THE BOILER

---

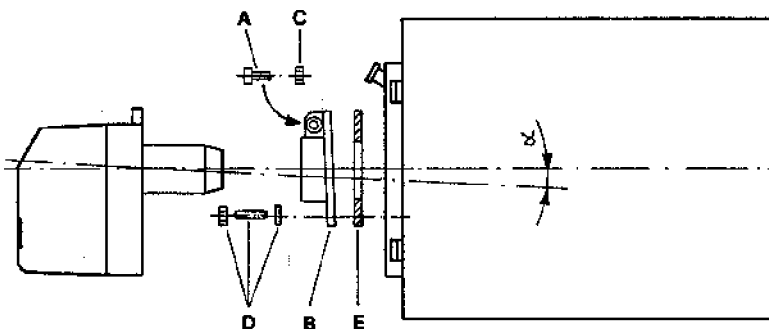

WITH SLIDING FLANGE:

- Fasten flange (B) to the boiler with n°4 screws (D) placing the insulation card (E);
- Insert burner into flange / boiler and tighten screw (A) with nut (C).

**CAUTION:** when attaching the burner to the flange, position the combustion head axis as illustrated in the diagram (angle  $\alpha$ ).

## CONTROL BOX SPECIFICATIONS

### Extraneous light / advanced ignition

During the pre-purging and/or pre-starting phase there shall be no flame signal. Should the signal be present, for example for advanced ignition due to bad tightness of the electrovalve, external lighting, short-circuit in the photo-resistance or in the connecting cable, a breakdown in the flame signal amplifier, and so on., when the pre-purging and safety time has elapsed, the control-box brings the burner to the emergency stop and cuts off fuel inflow even during the safety time.

### No flame

If there is no flame at the end of the safety time, the control-box stops the burner immediately.

### No flame during operation

If there is no flame during operation, the control-box cuts off fuel and automatically repeats a new starting program: once the "t4" time has elapsed, the starting program is over.

Every safety stop of less than 1 second switches off voltage to terminals 3 - 8 - 11: and to terminal 10, it is possible to provide a remote signal of emergency stop. Resetting of the control-box is possible after approx. 50 seconds of emergency stop.

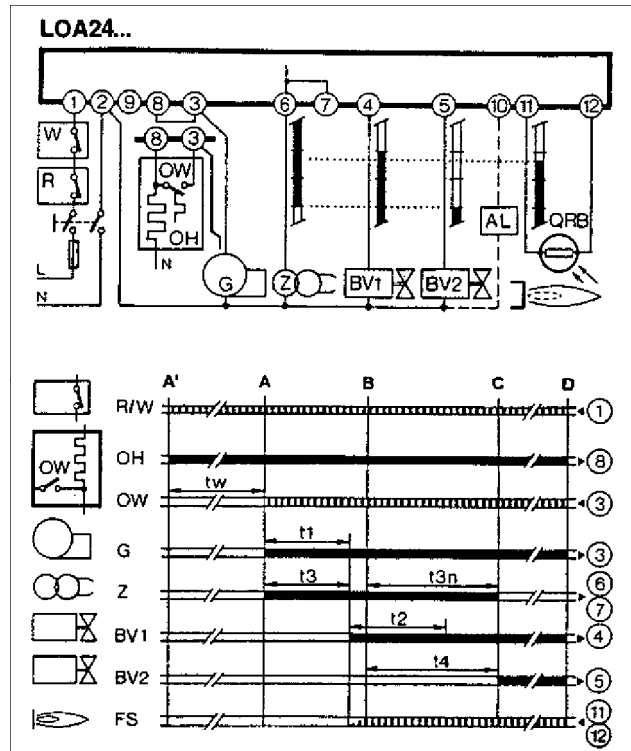

### Program Legend

■ Control-box output signals

□ Input signals required

A' Beginning of starting cycle for burners with light-oil pre-heater "OH"

A Beginning of starting cycle for burner without light-oil pre-heater

B Flame presence

C Normal operation

D Adjustment stop by "R"

tw Light-oil pre-heating time until operation consent by contact "OW" (minimum thermostat)

t1 Pre-purging time

t3 Pre-starting time

t2 Safety time

t3n Post-starting time

t4 Time interval between flame presence and connection of 2nd valve to terminal 5

Tension	Type	Safety at low voltage	Pre-purging	Pre-starting	Safety time	Post-starting	Time Interval
V ~			t1	t3	t2max	t3n	BV1-BV2=t4
220/240	LOA 24.171 B27	YES	13 s	13 s	10 s	15 s	15 s

## PREPARATIONS FOR START UP

Make sure that the return pipe in the tank has no obstructions, e.g. gate valves, closed plugs etc. Any eventual obstruction would cause a breakage in the sealing surface situated on the pump shaft. Close the main switch and the boiler thermostats in order to start up the motor and the ignition transformer. Upon completion of the pre-ventilation time, the solenoid valve is activated. The electrovalve will cut in and expose the photocell to a source of light until the burner stops (lock-out). When the pipelines have been filled up (and when fuel has come out of the nozzle), stop the burner and put the photocell back in its seat.

**NOTE:** Should it be necessary to purge air, this can be done by loosening the special fitting which the pump is provided with. Do not illuminate the photocell before the electric valve has cut in because, in this case, the control box will go to "lock-out".

## IGNITION AND ADJUSTMENT

Loosen the fixing screw "6" and bring the air damper into the position thought to be necessary as a function of the quantity of fuel to be burnt. Turn the main switch to ON to power the burner and thus ignite it. Correct, if necessary, combustion air delivery by acting on the intake damper and the position of the deflector disk (adjustable via screw 2). The burner is, in fact, fitted with a special screw to adjust the position of the deflector disk; this device allows for optimisation of combustion by reducing or increasing the air flow between the deflector disk and the head. It is normally necessary to reduce (undo screw 2) the air flow between the deflector disk and the head when there is reduced fuel delivery: this passage must be proportionately more open (screw in screw 2) when the burner is working with a higher fuel delivery rate. After modifying the position of the deflector disk it is, usually, necessary to correct the air damper positions and afterwards check for proper ignition. The burner is equipped with an on-nozzle light oil heater. This device provides better atomisation and thus better combustion.

### AIR REGULATION PRINCIPLE DIAGRAM AND DISK-ELECTRODES SETTING

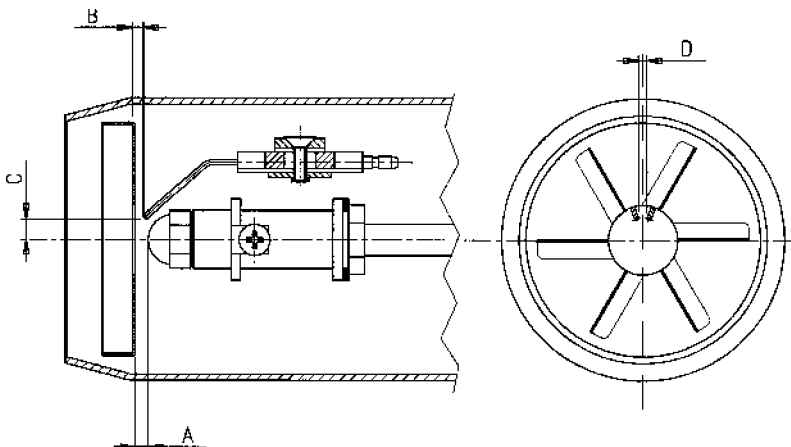

After having installed the nozzle, check the correct position of the electrodes and disk according to the following levels. It's advisable to check levels after every intervention on head.

**N.B. To prevent damage to the support or the pre-heater effect nozzle assembly/ disassembly tasks with the aid of a wrench and counter-wrench.**

	A	B	C	D
RiNOx 35	1	0	6	2.5

## COMBUSTION ADJUSTMENT

- 1 AIR REGISTER OPENING ADJUSTER
  - Reference index in position "0" register closed
  - Reference index in position "9" register open
- 2 FLAME DISC POSITION
- 3 AIR REGISTER OPENING ADJUSTER REFERENCE INDEX
- 4 AIR DAMPER IN OPEN POSITION (9)
- 5 AIR DAMPER IN CLOSED POSITION (0)
- 6 AIR DAMPER FIXING SCREW

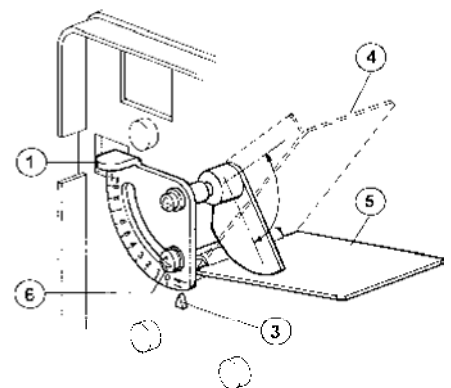

The DSV.2 pre-heater gives efficient pre-heating of the light oil and therefore ensures good ignition and stable, safe operation even at low ambient temperatures. It is provided with an incorporated solenoid cut-off valve and an anti-dripping device which is used for hydrocarbon (CxHy) during both ignition and burner shutdown.

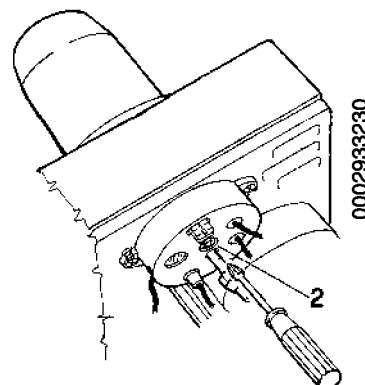

Burner model	ADJUSTMENT DATA				
	NOZZLE TYPE	Pump pressure	Burner flow-rate	3 Air gate adjustment	2 Disc position adjustment
	GPH	bar	kg/h	Set-point n°	Set-point n°
RINOx 35 (with pre-heating)	0.85	12	3.40	3.5	6
	0.75		2.90	2.5	4.5
	0.60		2.40	2	3
	0.50		1.80	1.5	0.5
	0.40		1.50	1	0.5

**NOTE:**

The values reported on this table are referred at the 12% CO<sub>2</sub> at the mean sea level and with 0.1 mbar pressure in the combustion chamber.

**NOTE:**

The values indicated in the table are purely indicative; for best burner performance adjustment needs to be made in accordance with the demands of the particular boiler type.

**RECOMMENDED NOZZLES**

STEINES type ..... S 60°  
 MONARCH type ..... R 60°  
 DAN FOSS type ..... S 60°

**MAINTENANCE**

Most components can be inspected by removing the hood. To inspect the head you must disassemble the component-carrying plate which can be hung on hung on the burner body in two different positions to make work as practical as possible. The motor, transformer and solenoid valve are connected via a connector while the photo-resistor is push-locked into place.

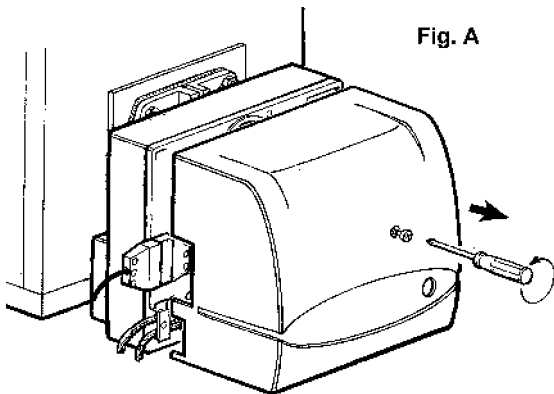

Fig. A

1) Undo the lid screw to gain access to the interior of the burner.

2) Undo the 4 screws of the plate, as indicated, in order to access nozzle, electrodes and pre-heater (if fitted).

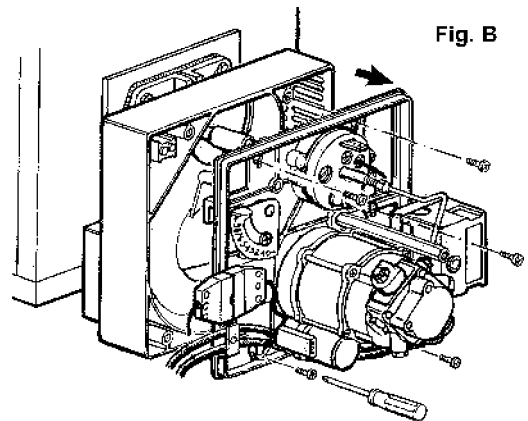

Fig. B

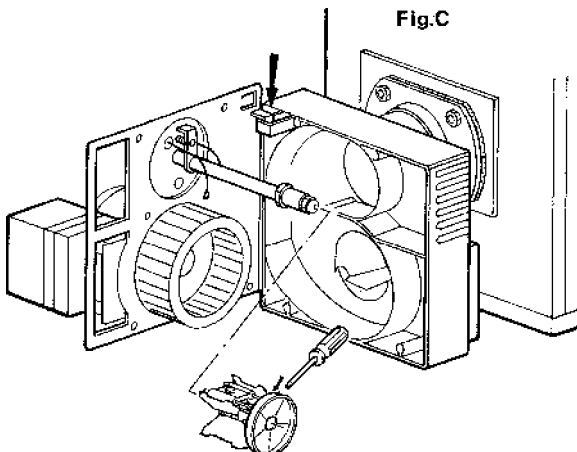
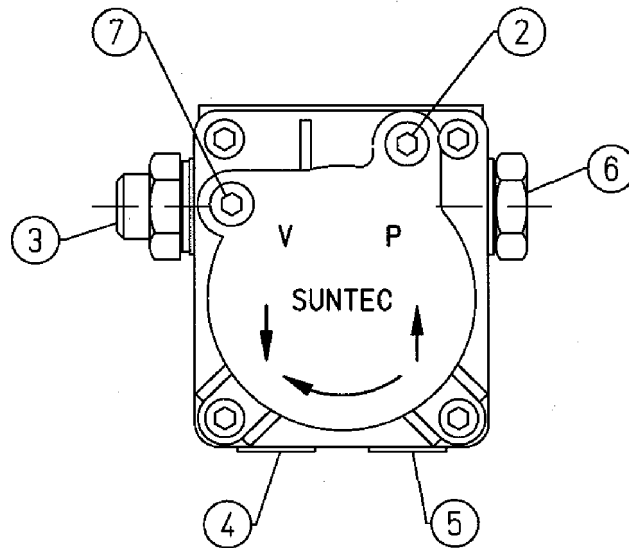

Fig. C

3) The plate must be hung up as illustrated in fig. C.

## PUMP SPECIFICATIONS

### SUNTEC AE 47C 1387



1. ELECTROVALVE (USUALLY CLOSED)
2. PRESSURE TEST POINT AND PURGE POINT (1/8")
3. PRESSURE REGULATION SCREW
4. RETURN
5. SUCTION
6. DELIVERY TO NOZZLE
7. VACUUM TEST POINT (1/8")

**N.B. The pump is preset at a 12 bar pressure.**

DETAILS of PROBLEM	POSSIBLE CAUSE	SOLUTION
The burner goes to "lock-out" with the flame on (red light on). Fault restricted to flame control device.	<ol style="list-style-type: none"> <li>1) Flame disc dirty or worn.</li> <li>2) Photocell dirty or greasy.</li> <li>3) Equipment fault.</li> <li>4) Photo resistor circuit failure.</li> </ol>	<ol style="list-style-type: none"> <li>1) Clean or replace it.</li> <li>2) Clean or replace it.</li> <li>3) Check all smoke circuits inside the boiler and the chimney.</li> <li>4) Replace the control box.</li> </ol>
The burner goes to "lock-out", oil flows out but there is no flame (red light on). Fault restricted to ignition circuit.	<ol style="list-style-type: none"> <li>1) Fault in ignition circuit.</li> <li>2) Ignition transformer cable discharges to earth.</li> <li>3) Ignition transformer cable disconnected.</li> <li>4) Ignition transformer faulty.</li> <li>5) The distance between electrode and earth is incorrect.</li> <li>6) Isolator dirty therefore the electrode discharges to earth.</li> </ol>	<ol style="list-style-type: none"> <li>1) Check the circuit completely.</li> <li>2) Replace.</li> <li>3) Connect.</li> <li>4) Replace.</li> <li>5) Position at the correct distance</li> <li>6) Clean or replace isolator and electrode.</li> </ol>
The burner goes to "lock-out", oil does not flow (red light on).	<ol style="list-style-type: none"> <li>1) One phase missing.</li> <li>2) Insufficient electric motor.</li> <li>3) Light oil does not reach the pump.</li> <li>4) No light oil inside the tank.</li> <li>5) Closed gate valve in suction pipe.</li> <li>6) Clogged nozzle.</li> <li>7) Motor rotating in the opposite direction as that indicated by the arrow.</li> </ol>	<ol style="list-style-type: none"> <li>1) Check the feeder line.</li> <li>2) Repair or replace it.</li> <li>3) Check the suction pipe.</li> <li>4) Fill with fuel</li> <li>5) Open it.</li> <li>6) Replace nozzle.</li> <li>7) Invert a phase in the input switch.</li> </ol>
The burner does not start.	<ol style="list-style-type: none"> <li>1) Open contact in thermostats or pressure switches.</li> <li>2) Photocell short circuits.</li> <li>3) There is no voltage because of an open contact in the main switch, the meter overload release or no voltage in line.</li> <li>4) The thermostats line was not carried out according to the diagram or thermostats did not close the contacts.</li> <li>5) Failure inside the control box.</li> </ol>	<ol style="list-style-type: none"> <li>1) Increase the value or wait for them to close by natural decrease in temperature or pressure.</li> <li>2) Replace.</li> <li>3) Close the contact of the switches or wait for voltage to be supplied again.</li> <li>4) Check thermostats connections.</li> <li>5) Replace.</li> </ol>
Defective flame with sparks.	<ol style="list-style-type: none"> <li>1) Spraying pressure is too low.</li> <li>2) Too much combustion air.</li> <li>3) Nozzle dirty or worn out.</li> <li>4) Water in fuel.</li> </ol>	<ol style="list-style-type: none"> <li>1) Bring it to the expected value.</li> <li>2) Decrease combustion air.</li> <li>3) Replace.</li> <li>4) Purge it from the tank by using a suitable pump (never use the burner pump to carry out this operation).</li> </ol>
Badly shaped flame with smoke and soot.	<ol style="list-style-type: none"> <li>1) Insufficient combustion air.</li> <li>2) Nozzle dirty or worn out.</li> <li>3) Clogged boiler pipe or chimney.</li> <li>4) Low spraying pressure.</li> </ol>	<ol style="list-style-type: none"> <li>1) Increase combustion air.</li> <li>2) Replace.</li> <li>3) Clean them.</li> <li>4) Bring to the correct value.</li> </ol>

# ELECTRIC DIAGRAM

## ELECTRIC CONNECTIONS

The electrical lines should be at an adequate distance from hot parts. It is advisable to make all the connections with flexible electric wire. Conductor's minimum section 1.5 mm<sup>2</sup>.

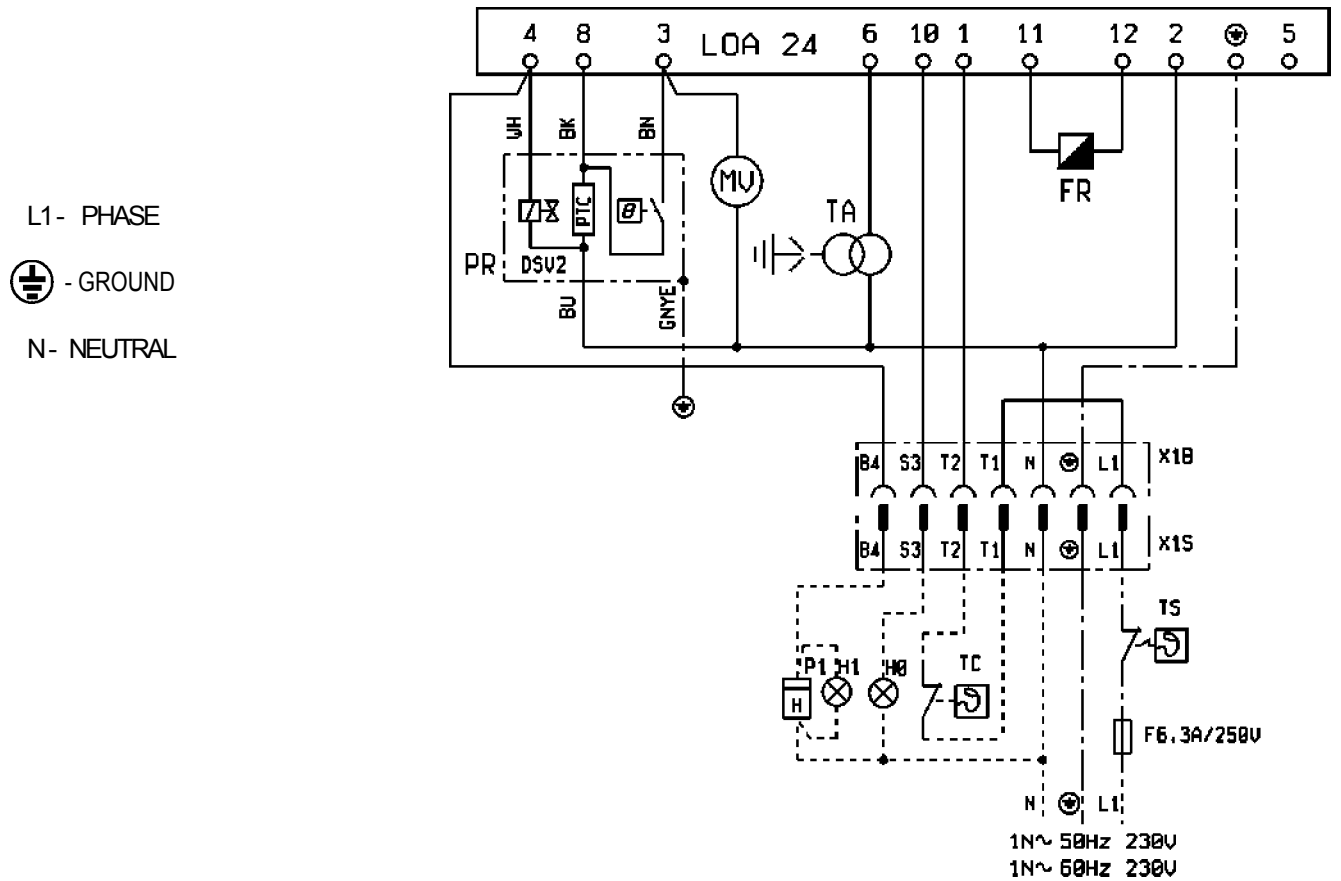

- L1- PHASE
- GROUND
- N- NEUTRAL

- H0 -Block Lamp
- H1 -Operation Light
- FR -Photocell
- TA -Ignition Transformer
- TS -Safety Thermostat
- TC -Boiler Thermostat
- LOA... -Control Box
- MV -Fan Motor
- P1 -Hour Meter
- PR -Oil Pre-heater

DIN/ IEC	(D)	(F)	(S)	(I)	(E)
GNYE	VERDE / SILVERO	VERT / JAUNE	GREEN / YELLOW	GRUEN / GELB	VERDE / AMBILO
UH	BIANCO	BLANC	WHITE	WEISS	BLANCO
BU	BLU	BLEU	BLUE	BLAU	AZUL
BN	BRUNO	BRUN	BROWN	BRAUN	MARRÓN
BK	NERO	NOIR	BLACK	SCHWARZ	NEGRO
BK #	CONDUCTORE NERO CON SOVRASTAMPA	CONDUCTEUR NOIR AVEC IMPRESSIION	BLACK WIRE WITH IMPRINT	SCHWARZ ADRP MIT RUFDRUCK	CONDUCTOR NEGRO CON IMPRESSIION

## NOZZLE FLOW-RATE TABLE FOR LIGHT OIL

Nozzle	Pump Pressure															Nozzle
	bar															
	7	8	9	10	11	12	13	14	15	16	17	18	19	20	21	
G.P.H.	Nozzle output flow-rate															G.P.H.
	kg/h															
<b>0.40</b>	<b>1.27</b>	<b>1.36</b>	<b>1.44</b>	<b>1.52</b>	<b>1.59</b>	<b>1.67</b>	<b>1.73</b>	<b>1.80</b>	<b>1.86</b>	<b>1.92</b>	<b>1.98</b>	<b>2.04</b>	<b>2.10</b>	<b>2.15</b>	<b>2.20</b>	<b>0.40</b>
0.50	1.59	1.70	1.80	1.90	1.99	2.08	2.17	2.25	2.33	2.40	2.48	2.55	2.62	2.69	2.75	0.50
<b>0.60</b>	<b>1.91</b>	<b>2.04</b>	<b>2.16</b>	<b>2.28</b>	<b>2.39</b>	<b>2.50</b>	<b>2.60</b>	<b>2.70</b>	<b>2.79</b>	<b>2.88</b>	<b>2.97</b>	<b>3.06</b>	<b>3.14</b>	<b>3.22</b>	<b>3.30</b>	<b>0.60</b>
0.65	2.07	2.21	2.34	2.47	2.59	2.71	2.82	2.92	3.03	3.12	3.22	3.31	3.41	3.49	3.58	0.65
<b>0.75</b>	<b>2.38</b>	<b>2.55</b>	<b>2.70</b>	<b>2.85</b>	<b>2.99</b>	<b>3.12</b>	<b>3.25</b>	<b>3.37</b>	<b>3.49</b>	<b>3.61</b>	<b>3.72</b>	<b>3.82</b>	<b>3.93</b>	<b>4.03</b>	<b>4.13</b>	<b>0.75</b>
0.85	2.70	2.89	3.06	3.23	3.39	3.54	3.68	3.82	3.96	4.09	4.21	4.33	4.45	4.57	4.68	0.85
<b>1.00</b>	<b>3.18</b>	<b>3.40</b>	<b>3.61</b>	<b>3.80</b>	<b>3.99</b>	<b>4.16</b>	<b>4.33</b>	<b>4.50</b>	<b>4.65</b>	<b>4.81</b>	<b>4.96</b>	<b>5.10</b>	<b>5.24</b>	<b>5.37</b>	<b>5.51</b>	<b>1.00</b>
1.10	3.50	3.74	3.97	4.18	4.38	4.58	4.77	4.95	5.12	5.29	5.45	5.61	5.76	5.91	6.06	1.10
<b>1.20</b>	<b>3.82</b>	<b>4.08</b>	<b>4.33</b>	<b>4.56</b>	<b>4.78</b>	<b>5.00</b>	<b>5.20</b>	<b>5.40</b>	<b>5.59</b>	<b>5.77</b>	<b>5.95</b>	<b>6.12</b>	<b>6.29</b>	<b>6.45</b>	<b>6.61</b>	<b>1.20</b>
1.25	3.97	4.25	4.50	4.75	5.00	5.20	5.40	5.60	5.80	6.00	6.20	6.35	6.55	6.70	6.85	1.25
<b>1.35</b>	<b>4.29</b>	<b>4.59</b>	<b>4.87</b>	<b>5.13</b>	<b>5.38</b>	<b>5.62</b>	<b>5.85</b>	<b>6.07</b>	<b>6.28</b>	<b>6.49</b>	<b>6.69</b>	<b>6.88</b>	<b>7.07</b>	<b>7.26</b>	<b>7.44</b>	<b>1.35</b>
1.50	4.77	5.10	5.41	5.70	5.90	6.24	6.50	6.75	6.98	7.21	7.43	7.65	7.86	8.06	8.26	1.50
<b>1.65</b>	<b>5.25</b>	<b>5.61</b>	<b>5.95</b>	<b>6.27</b>	<b>6.58</b>	<b>6.87</b>	<b>7.15</b>	<b>7.42</b>	<b>7.68</b>	<b>7.93</b>	<b>8.18</b>	<b>8.41</b>	<b>8.64</b>	<b>8.87</b>	<b>9.09</b>	<b>1.65</b>
1.75	5.56	5.95	6.31	6.65	6.98	7.29	7.58	7.87	8.15	8.41	8.67	8.92	9.17	9.41	9.64	1.75
<b>2.00</b>	<b>6.30</b>	<b>6.80</b>	<b>7.21</b>	<b>7.60</b>	<b>7.97</b>	<b>8.33</b>	<b>8.67</b>	<b>8.99</b>	<b>9.31</b>	<b>9.61</b>	<b>9.91</b>	<b>10.20</b>	<b>10.48</b>	<b>10.75</b>	<b>11.01</b>	<b>2.00</b>
2.25	7.15	7.65	8.15	8.55	8.97	9.37	9.75	10.12	10.47	10.85	11.15	11.47	11.79	12.09	12.39	2.25
<b>2.50</b>	<b>7.95</b>	<b>8.50</b>	<b>9.01</b>	<b>9.50</b>	<b>9.97</b>	<b>10.41</b>	<b>10.83</b>	<b>11.24</b>	<b>11.64</b>	<b>12.02</b>	<b>12.39</b>	<b>12.75</b>	<b>13.10</b>	<b>13.44</b>	<b>13.77</b>	<b>2.50</b>
3.00	9.54	10.20	10.82	11.40	11.96	12.49	13.00	13.49	13.96	14.02	14.87	15.30	15.72	16.12	16.52	3.00
<b>3.50</b>	<b>11.13</b>	<b>11.90</b>	<b>12.62</b>	<b>13.30</b>	<b>13.95</b>	<b>14.57</b>	<b>15.17</b>	<b>15.74</b>	<b>16.29</b>	<b>16.83</b>	<b>17.34</b>	<b>17.85</b>	<b>18.34</b>	<b>18.81</b>	<b>19.28</b>	<b>3.50</b>
4.00	12.72	13.60	14.42	15.20	15.94	16.65	17.33	17.99	18.62	19.23	19.82	20.40	20.95	21.50	22.03	4.00
<b>4.50</b>	<b>14.31</b>	<b>15.30</b>	<b>16.22</b>	<b>17.10</b>	<b>17.94</b>	<b>18.73</b>	<b>19.50</b>	<b>20.24</b>	<b>20.95</b>	<b>21.63</b>	<b>22.30</b>	<b>22.95</b>	<b>23.57</b>	<b>24.19</b>	<b>24.78</b>	<b>4.50</b>
5.00	15.90	17.00	18.03	19.00	19.93	20.82	21.67	22.48	23.27	24.04	24.78	25.49	26.19	26.87	27.54	5.00
<b>5.50</b>	<b>17.49</b>	<b>18.70</b>	<b>19.83</b>	<b>20.90</b>	<b>21.92</b>	<b>22.90</b>	<b>23.83</b>	<b>24.73</b>	<b>25.60</b>	<b>26.44</b>	<b>27.25</b>	<b>28.04</b>	<b>28.81</b>	<b>29.56</b>	<b>30.29</b>	<b>5.50</b>
6.00	19.00	20.40	21.63	22.80	23.92	24.98	26.00	26.98	27.93	28.84	29.73	30.59	31.43	32.25	33.04	6.00
<b>6.50</b>	<b>20.67</b>	<b>22.10</b>	<b>23.44</b>	<b>23.70</b>	<b>25.91</b>	<b>27.06</b>	<b>28.17</b>	<b>29.23</b>	<b>30.26</b>	<b>31.25</b>	<b>32.21</b>	<b>33.14</b>	<b>34.05</b>	<b>34.94</b>	<b>35.80</b>	<b>6.50</b>
7.00	22.26	23.79	25.24	26.60	27.90	29.14	30.33	31.48	32.58	33.65	34.69	35.69	36.67	37.62	38.55	7.00
<b>7.50</b>	<b>23.85</b>	<b>25.49</b>	<b>27.04</b>	<b>28.50</b>	<b>29.90</b>	<b>31.22</b>	<b>32.50</b>	<b>33.73</b>	<b>34.91</b>	<b>36.05</b>	<b>37.16</b>	<b>38.24</b>	<b>39.29</b>	<b>40.31</b>	<b>41.31</b>	<b>7.50</b>
8.30	26.39	28.21	29.93	31.54	33.08	34.55	35.97	37.32	38.63	39.90	41.13	42.32	43.48	44.61	45.71	8.30
<b>9.50</b>	<b>30.21</b>	<b>32.29</b>	<b>34.25</b>	<b>36.10</b>	<b>37.87</b>	<b>39.55</b>	<b>41.17</b>	<b>42.72</b>	<b>44.22</b>	<b>45.67</b>	<b>47.07</b>	<b>48.44</b>	<b>49.77</b>	<b>51.06</b>	<b>52.32</b>	<b>9.50</b>
10.50	33.39	35.69	37.86	40.06	41.73	43.74	45.41	47.20	48.90	50.50	52.00	53.50	55.00	56.40	57.80	10.50
<b>12.00</b>	<b>38.20</b>	<b>40.80</b>	<b>43.30</b>	<b>45.60</b>	<b>47.80</b>	<b>50.00</b>	<b>52.00</b>	<b>54.00</b>	<b>55.90</b>	<b>57.70</b>	<b>59.50</b>	<b>61.20</b>	<b>62.90</b>	<b>64.50</b>	<b>66.10</b>	<b>12.00</b>
13.80	43.90	46.90	49.80	52.40	55.00	57.50	59.80	62.10	64.20	66.30	68.40	70.40	72.30	74.30	76.00	13.80
<b>15.30</b>	<b>48.60</b>	<b>52.00</b>	<b>55.20</b>	<b>58.10</b>	<b>61.00</b>	<b>63.70</b>	<b>66.30</b>	<b>68.80</b>	<b>71.10</b>	<b>73.60</b>	<b>75.80</b>	<b>78.00</b>	<b>80.20</b>	<b>82.20</b>	<b>84.30</b>	<b>15.30</b>
17.50	55.60	59.50	63.10	66.50	69.80	72.90	75.80	78.70	81.50	84.10	86.70	89.20	91.70	94.10	96.40	17.50
<b>19.50</b>	<b>62.00</b>	<b>66.30</b>	<b>70.30</b>	<b>74.10</b>	<b>77.70</b>	<b>81.20</b>	<b>84.50</b>	<b>87.70</b>	<b>90.80</b>	<b>93.70</b>	<b>96.60</b>	<b>99.40</b>	<b>102.20</b>	<b>104.80</b>	<b>107.40</b>	<b>19.50</b>
21.50	68.40	73.10	77.50	81.70	85.70	89.50	93.20	96.70	100.10	103.40	106.50	109.60	112.60	115.60	118.40	21.50
<b>24.00</b>	<b>76.30</b>	<b>81.60</b>	<b>86.50</b>	<b>91.20</b>	<b>95.70</b>	<b>99.90</b>	<b>104.00</b>	<b>107.90</b>	<b>111.70</b>	<b>115.40</b>	<b>118.90</b>	<b>122.40</b>	<b>125.70</b>	<b>129.00</b>	<b>132.20</b>	<b>24.00</b>
28.00	89.00	95.20	101.00	106.40	111.60	116.60	121.30	125.90	130.30	134.60	138.70	142.80	146.70	150.50	154.20	28.00
<b>30.00</b>	<b>95.40</b>	<b>102.00</b>	<b>108.20</b>	<b>114.00</b>	<b>119.60</b>	<b>124.90</b>	<b>130.00</b>	<b>134.90</b>	<b>139.60</b>	<b>144.20</b>	<b>148.70</b>	<b>153.00</b>	<b>157.20</b>	<b>161.20</b>	<b>165.20</b>	<b>30.00</b>

1 mbar= 10 mmC.A.  $\approx$  100 Pa  
 kW= 860 kcal

Light Oil Density = 0,820 / 0,830 PCI = 10150  
 Special Heating Oil Density = 0,900 PCI = 9920  
 Domestic (3,5°E) Heating Oil Density = 0,940 PCI = 9700  
 Heavy Oil Density (7,9°E) = 0,970 / 0,980 PCI = 9650

PCI = Minimum Calorific Value



**EOGB Energy Products Ltd**  
5 Howard Road,  
Eaton Socon,  
St. Neots,  
Cams.  
PE19 8ET

Telephone: 08703 899499  
Facsimile: 01480 477022  
Website: [www.eogb.co.uk](http://www.eogb.co.uk)

